

# A propos de la céramique traditionnelle de la boucle du Niger (Mali)



## 4. DIFFUSION DE LA POTERIE EN PAYS DOGON Traditions C, D et E

Alain Gallay, Université de Genève



© MAESAO

# TRADITION C : femmes de forgerons Jèmè Yélin

	Caractéristiques intrinsèques	Caractéristiques extrinsèques		
Nouvelles dénominations	Techniques génériques	Groupe social	Langue	Région
Tradition C1	1. Montage en anneau 2. Modelage 3. Pilonnage sur forme convexe	Forgerons des Tomo	Tomo kan Donno sò	Plateau et Falaise de Bandiagara
Tradition C2	1. Montage en anneau 2. Modelage	Forgerons des Tomo	Tomo kan Togo kan	Plaine du Séno
Tradition C2	1. Montage en anneau 2. Modelage	Forgerons des Dafi	Dioula	Plaine du Séno

Tradition C2 (plaine du Séno) : pas de pilonnage sur forme convexe

# TRADITION C : géographie, femmes de forgerons Jèmè yélin

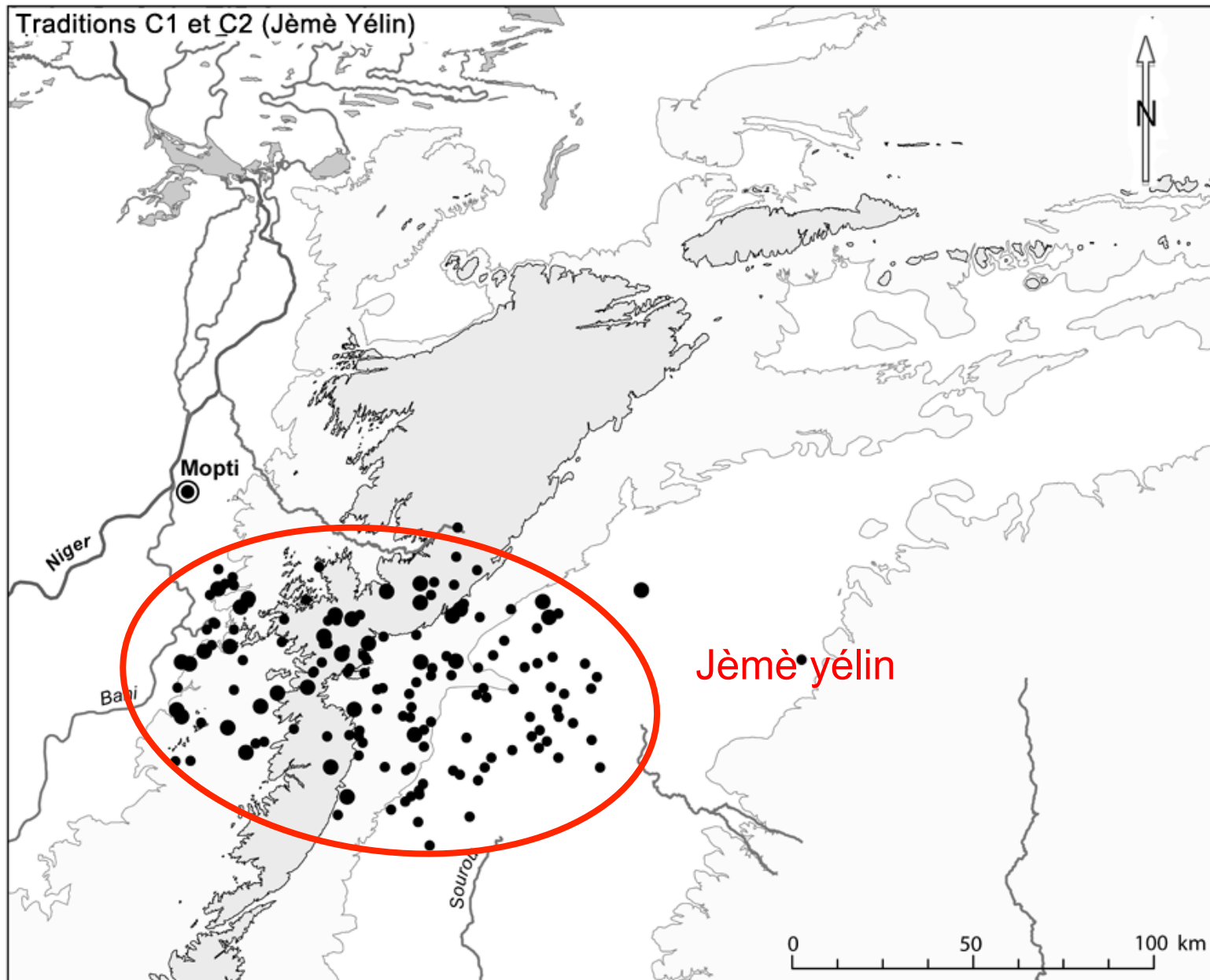

# TRADITION C : géographie, femmes de forgerons Dafi

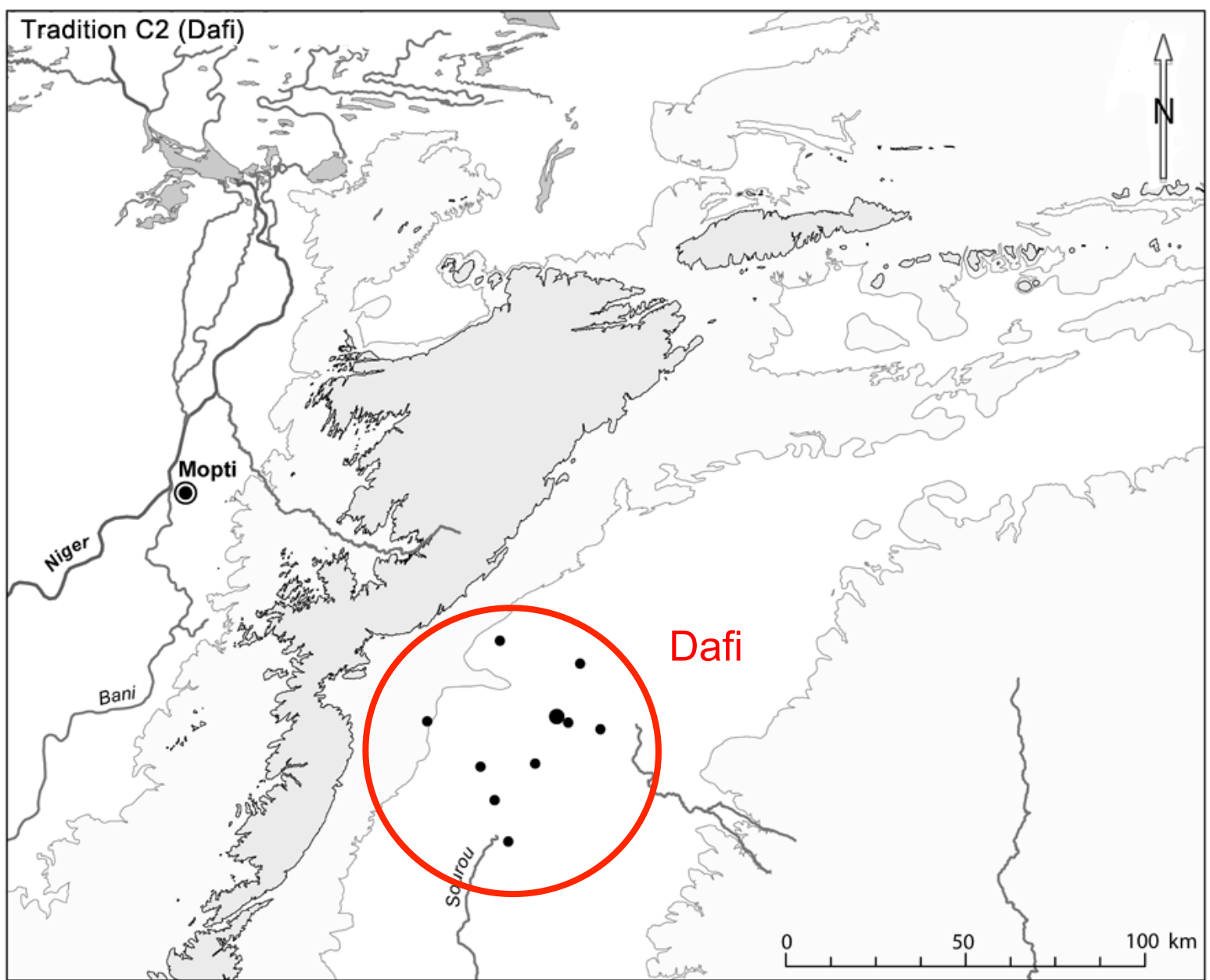



# TRADITION C : géographie : femmes de forgerons Jèmè yélin, Irin et Dafi

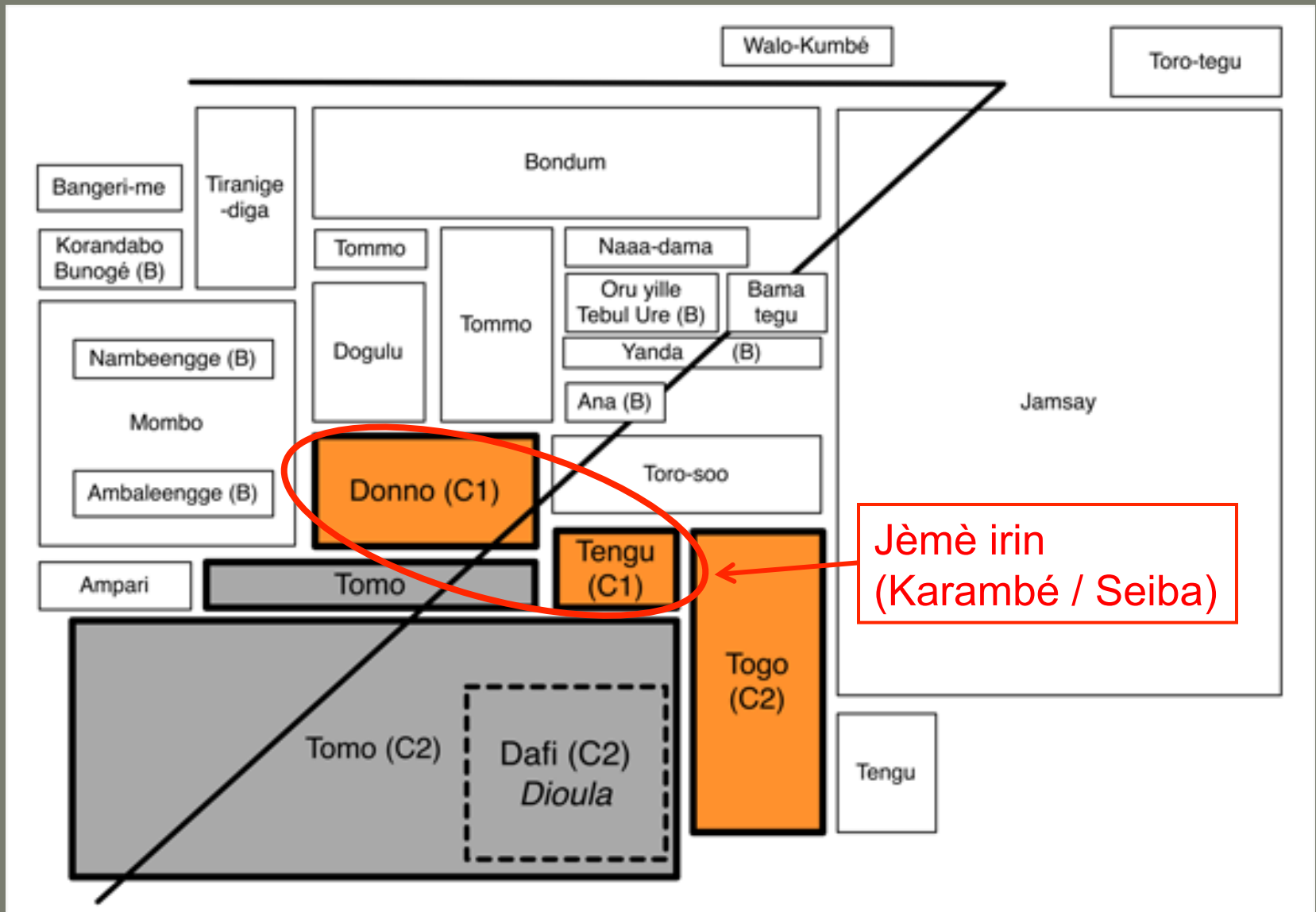

# TRADITION C : typologie



# TRADITION C : typologie, femmes de forgerons Jème yélin (C1/C2)

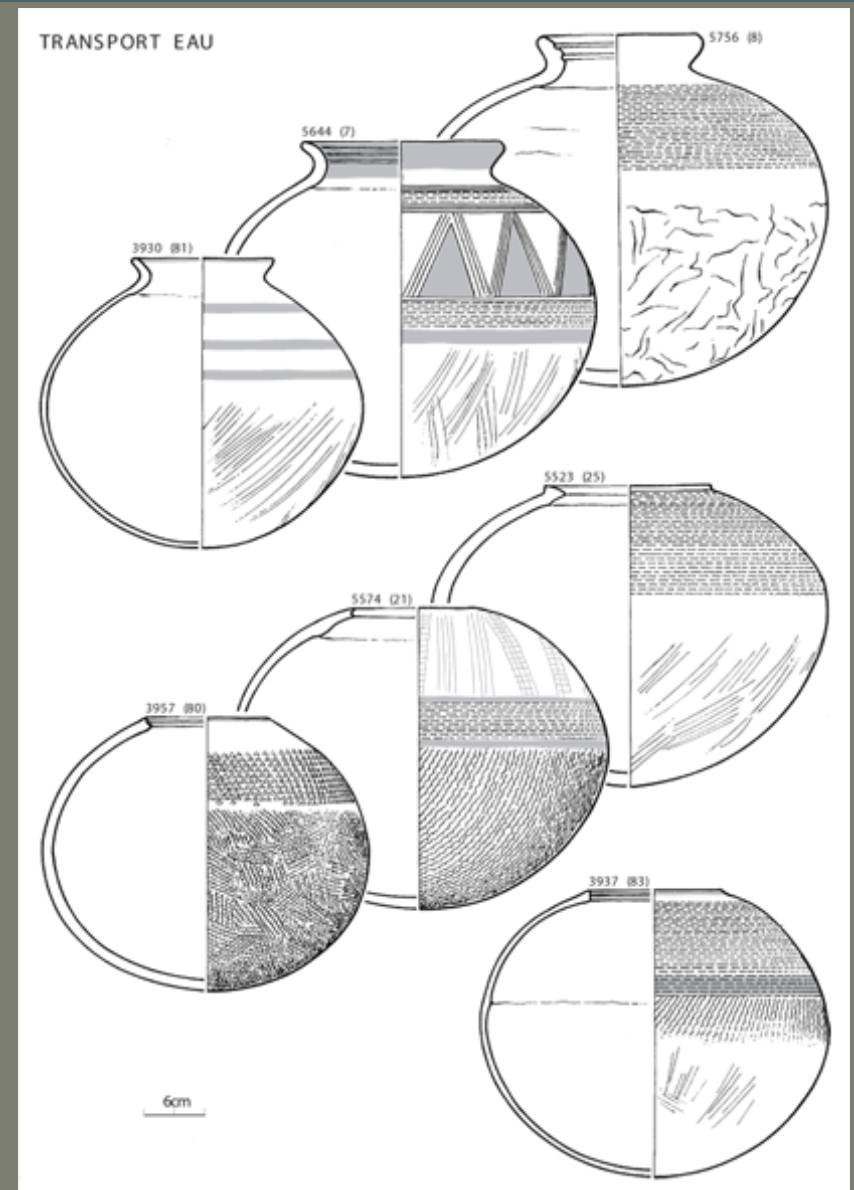
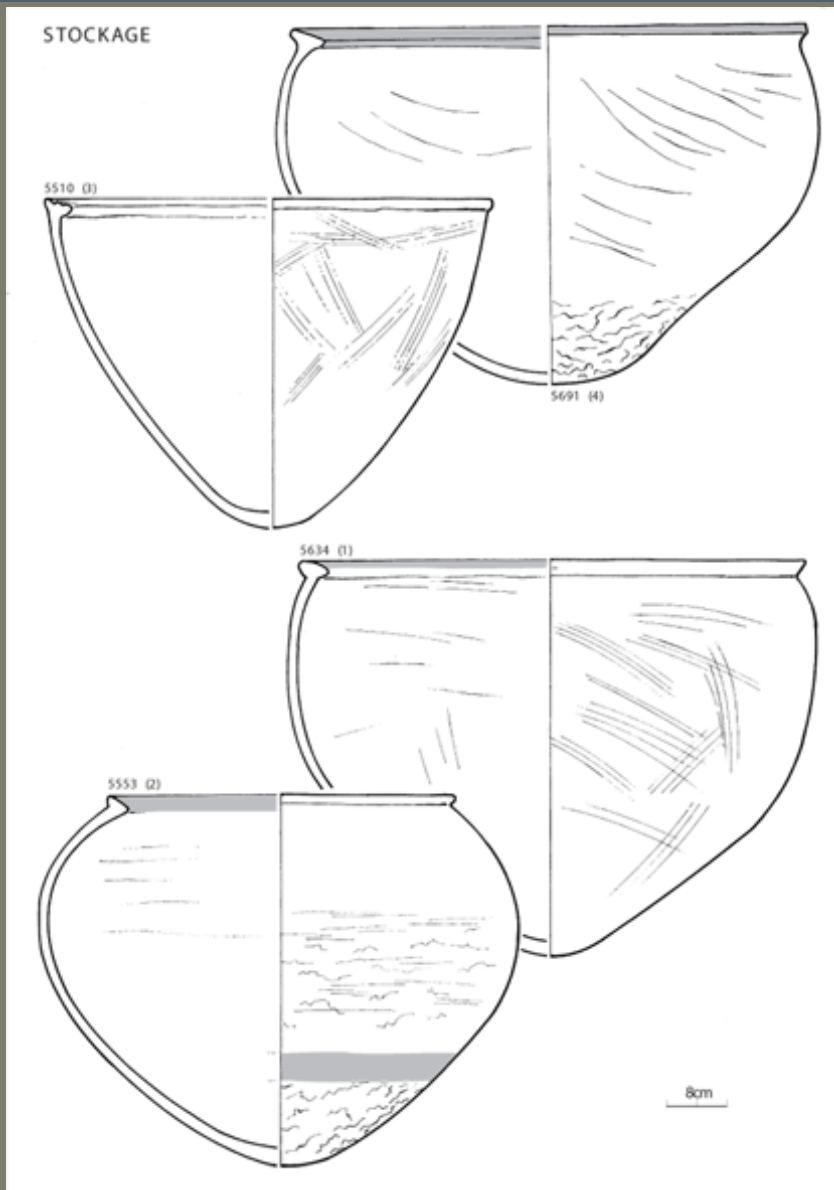



# TRADITION C : typologie, décors (C1 et C2)

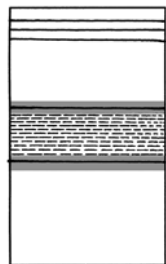

17

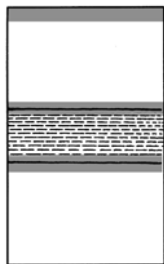

18

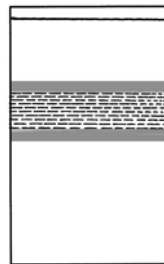

19

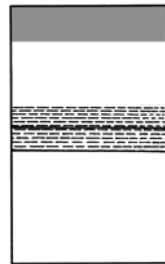

20

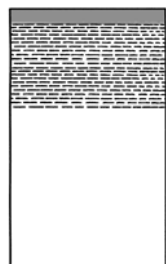

21

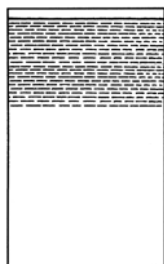

22

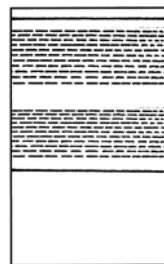

23

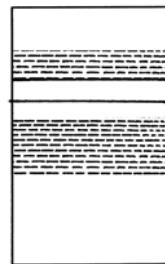

24

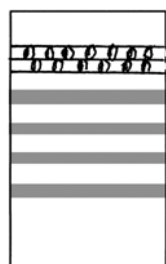

25



26

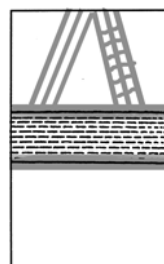

27

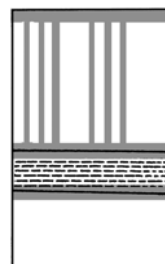

28

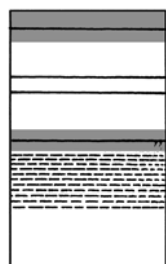

29

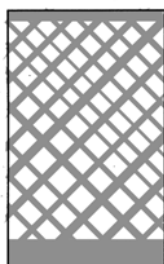

30

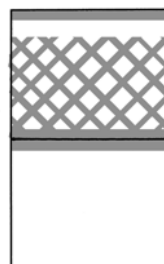

31

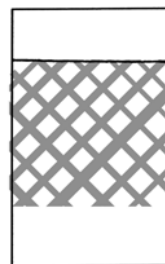

32

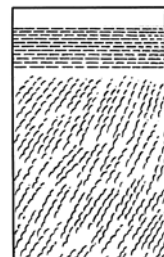

49

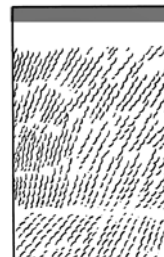

50

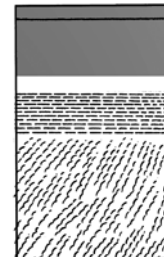

51

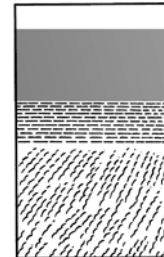

52

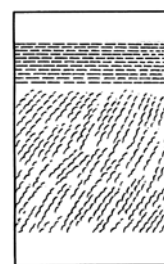

53

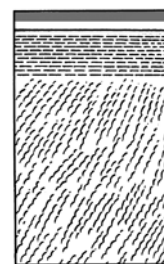

54

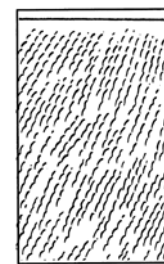

55

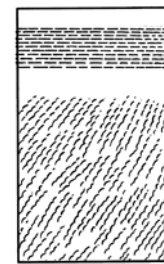

56

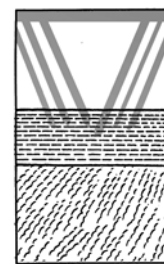

57

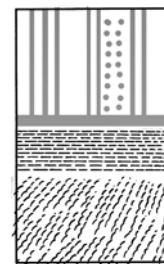

58



59

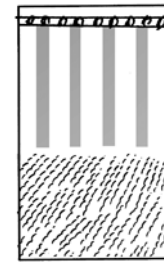

60

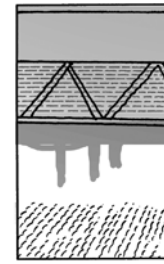

61

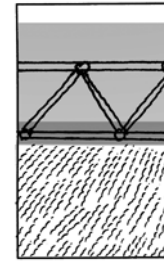

62

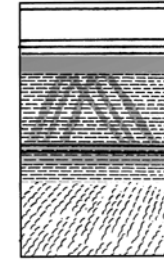

63

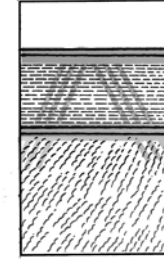

64

# TRADITION C : typologie décors (C1 et C2)

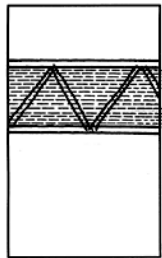

65

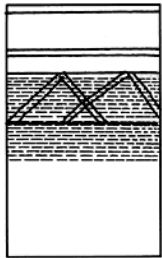

66

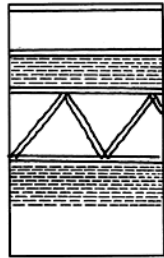

67

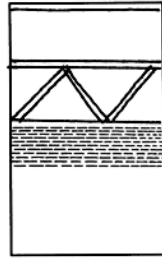

68



69

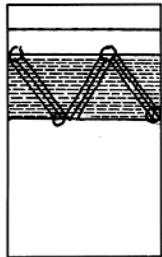

70

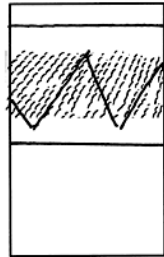

71

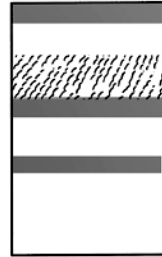

72

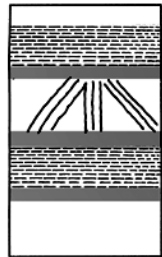

73

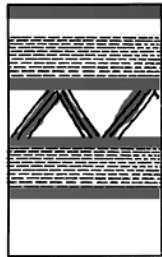

74

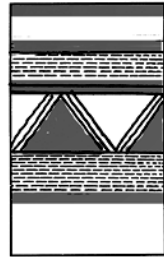

75

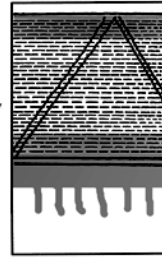

76

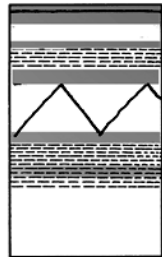

77

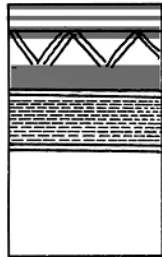

78

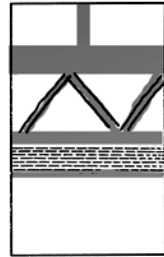

79



80



# TRADITION C : fabrication, montage, pilonnage sur forme convexe



# TRADITION C : fabrication, montages, modelage



# TRADITION C : fabrication, montage en anneau



1. Colombin de fond



2. Etirement



3. Obturation du fond



4. Montage au colombin

# TRADITION C : fabrication, montages, instruments

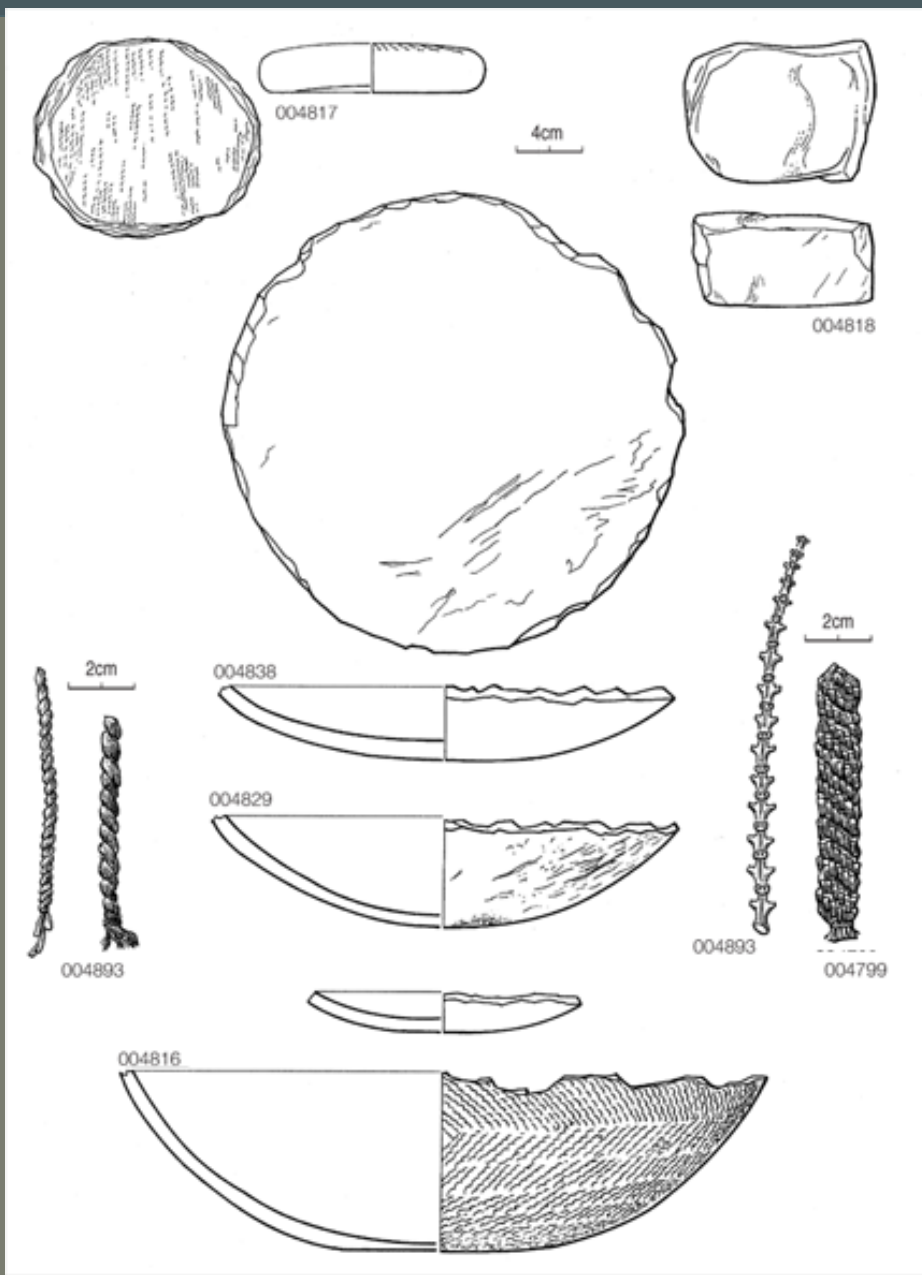

# TRADITION C : fabrication, cuisson, Dafi

DOGON C2 ( Dafi )  
Dongolé

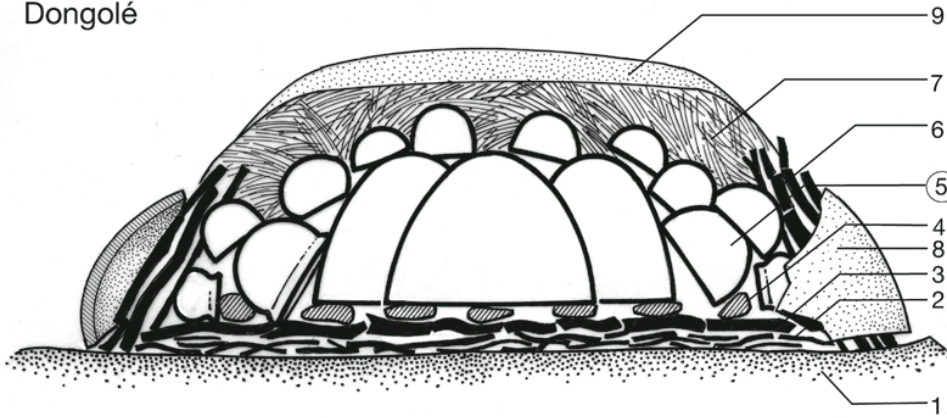

# TRADITION C : transmission, Jèmè yélin

## Distances matrimoniales

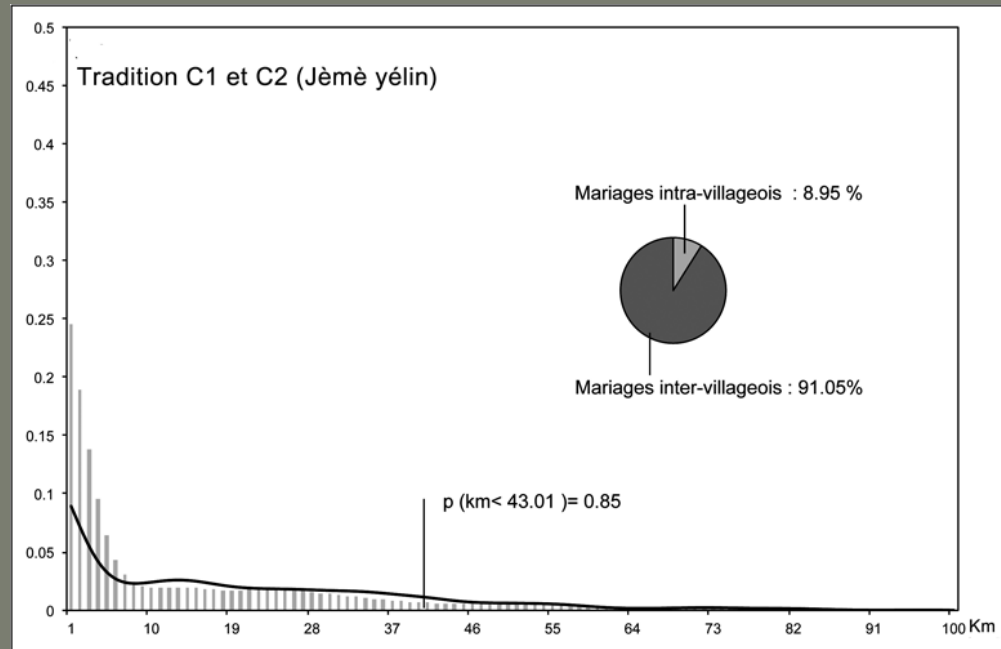
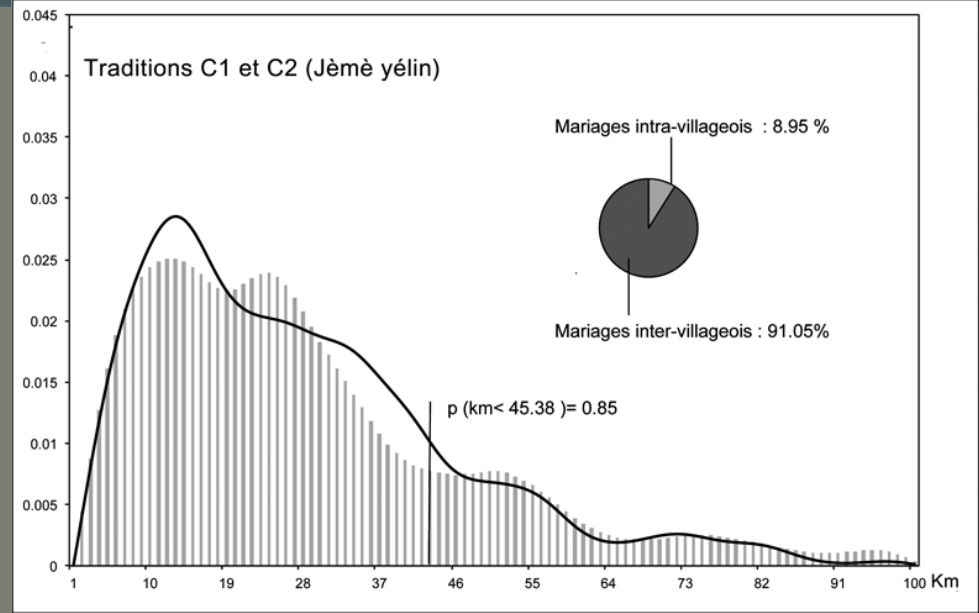



# TRADITION C : transmission, Dafi

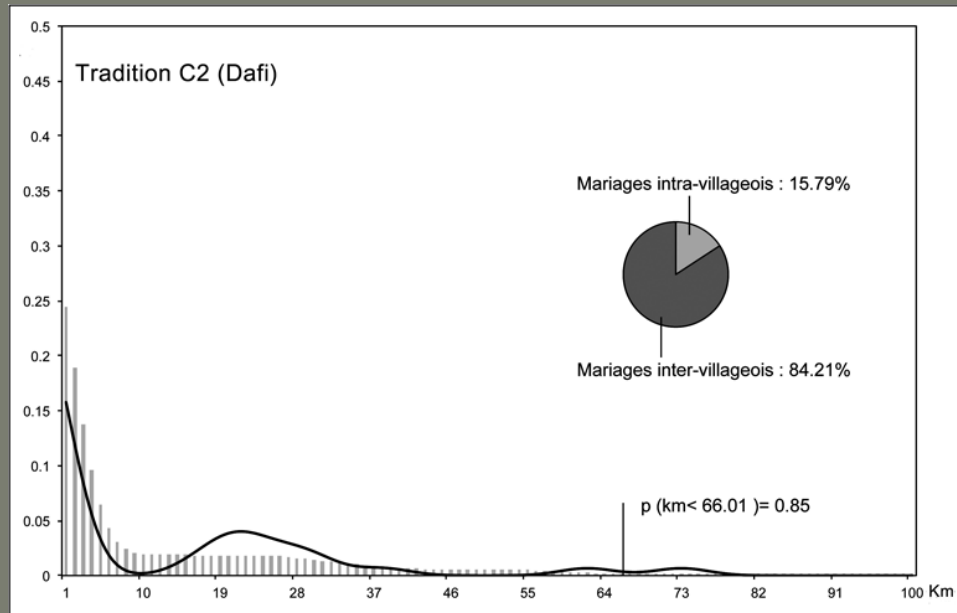
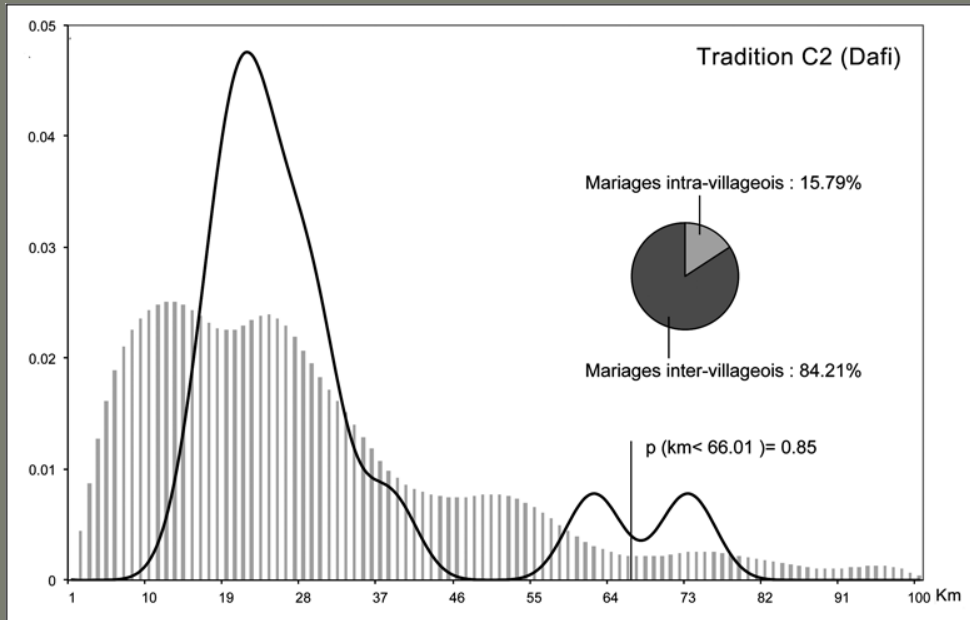

# TRADITION C : femmes de forgerons Jèmè yélin, endogamie patronymiques ?

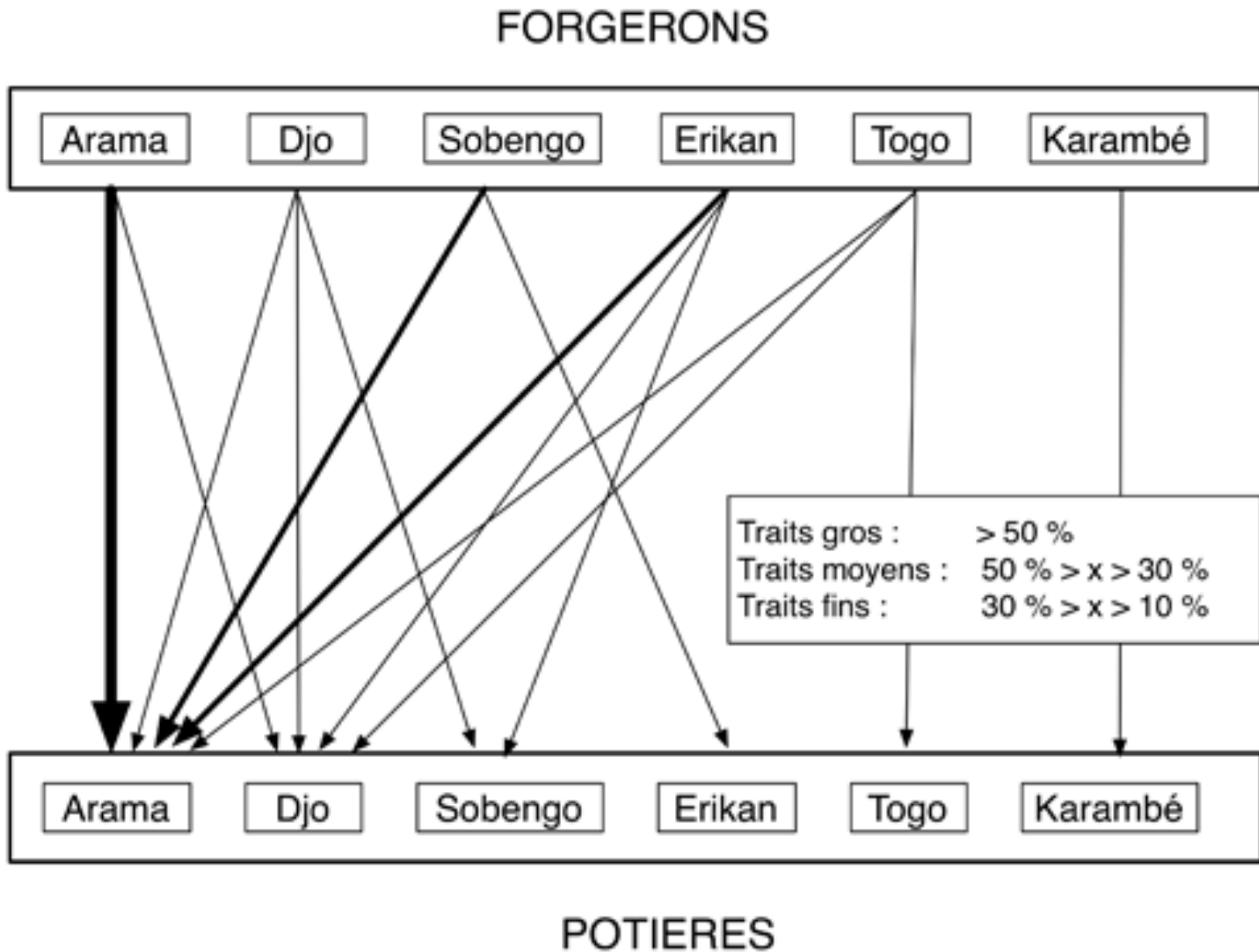

# TRADITION C : femmes de forgerons Jèmè yélin, endogamie patronymiques ?

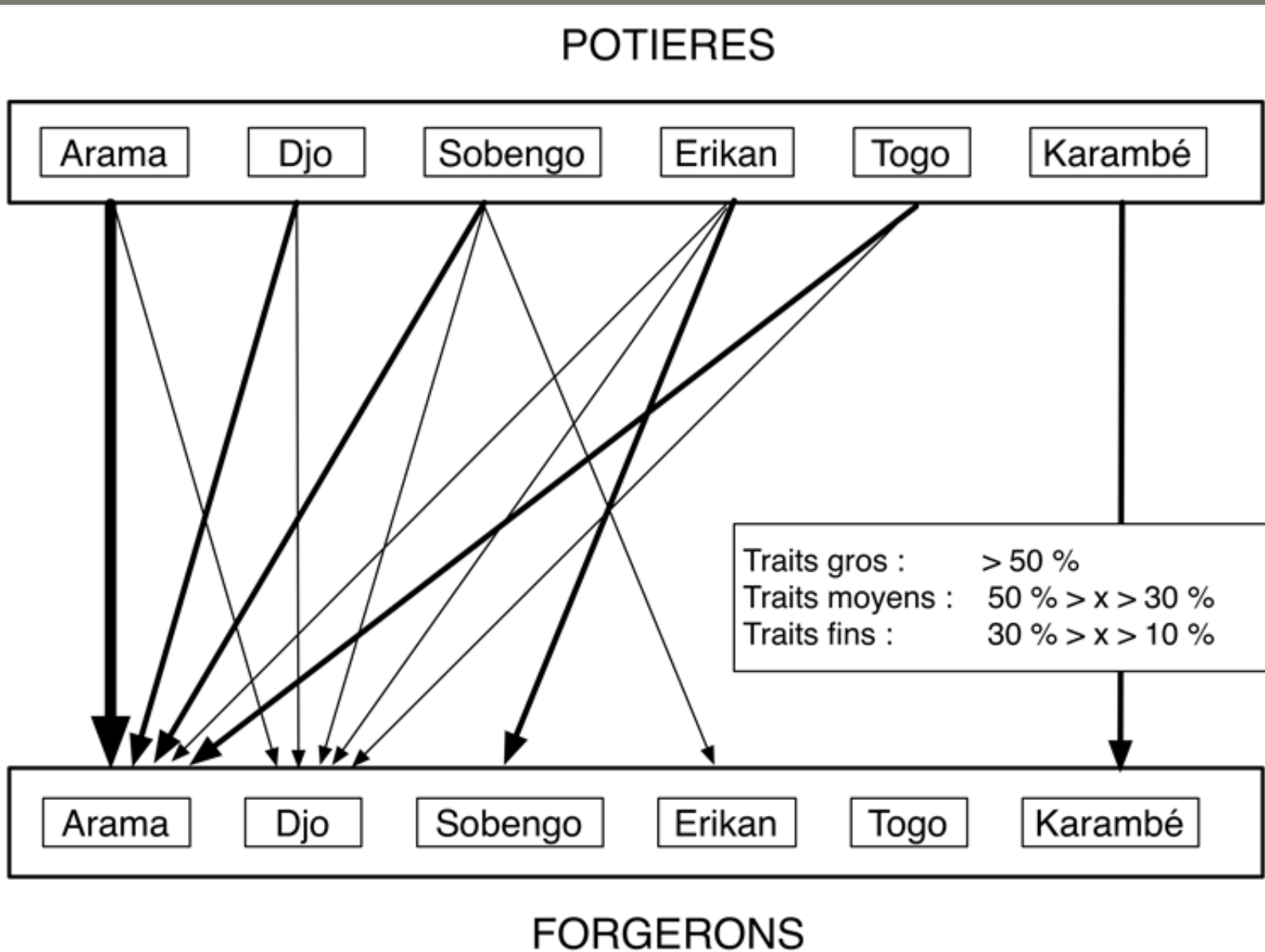

# TRADITION C : transmission

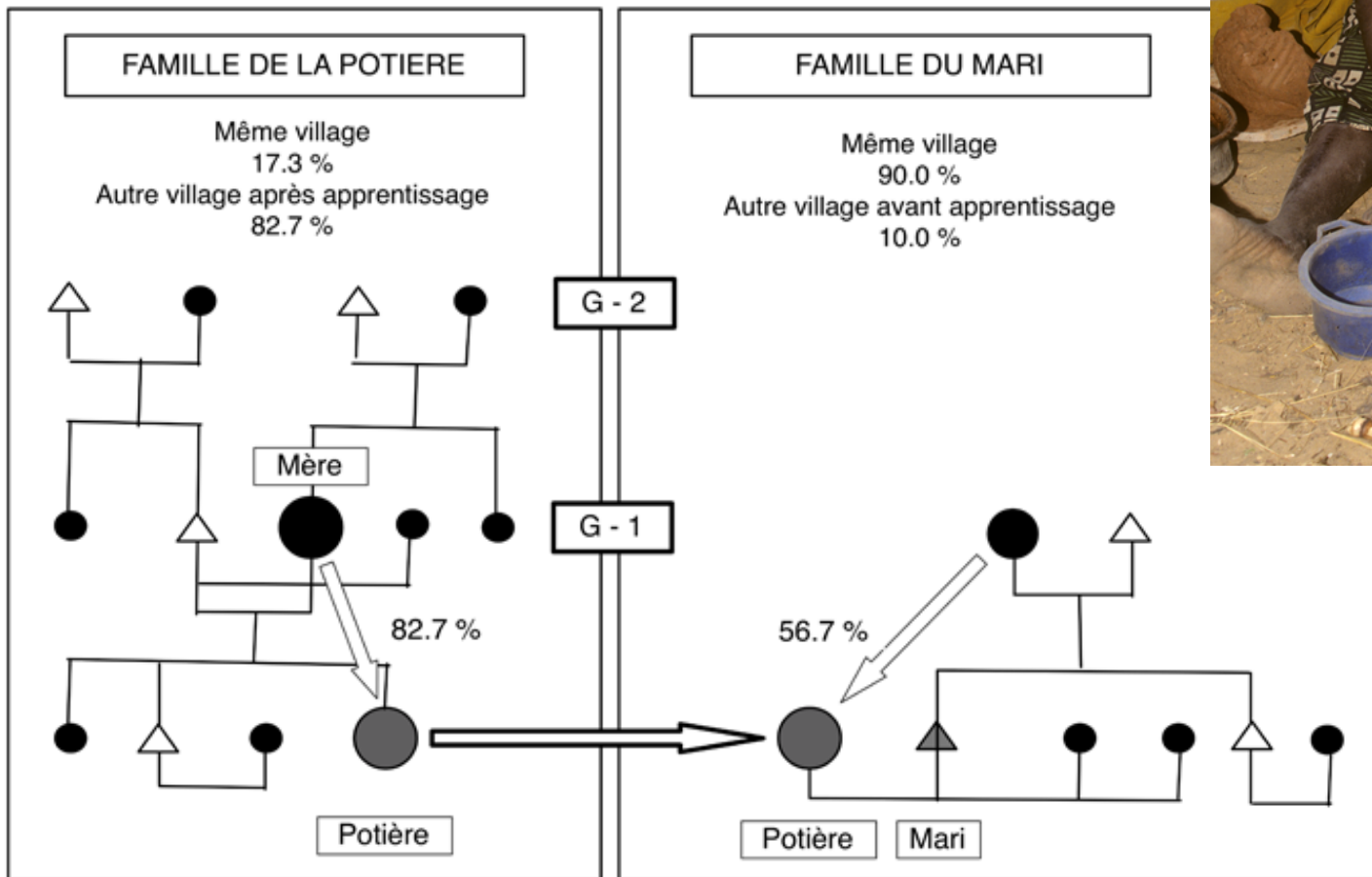

# TRADITION C : transmission

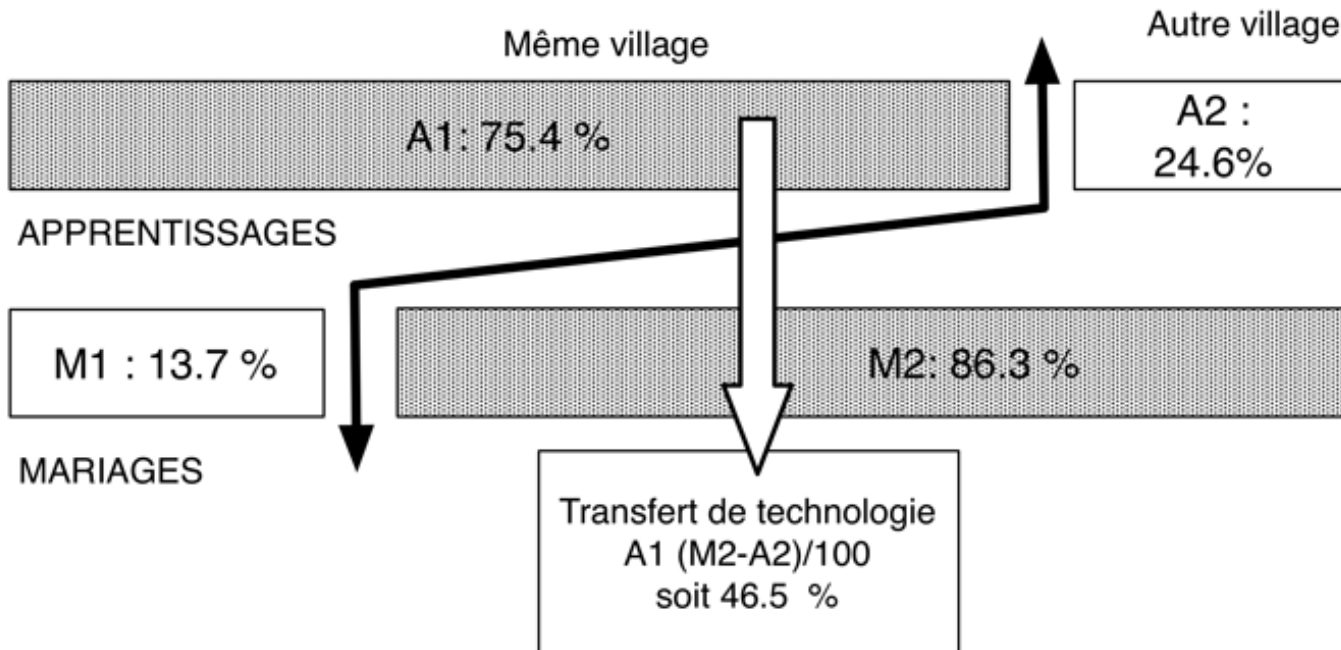

A : 22.4 %  
D : 35.7 %  
C : 46.5 %  
B1 : 60.6 %  
B2 : 60.7 %

# TRADITION C : fabrication

## Atelier 1

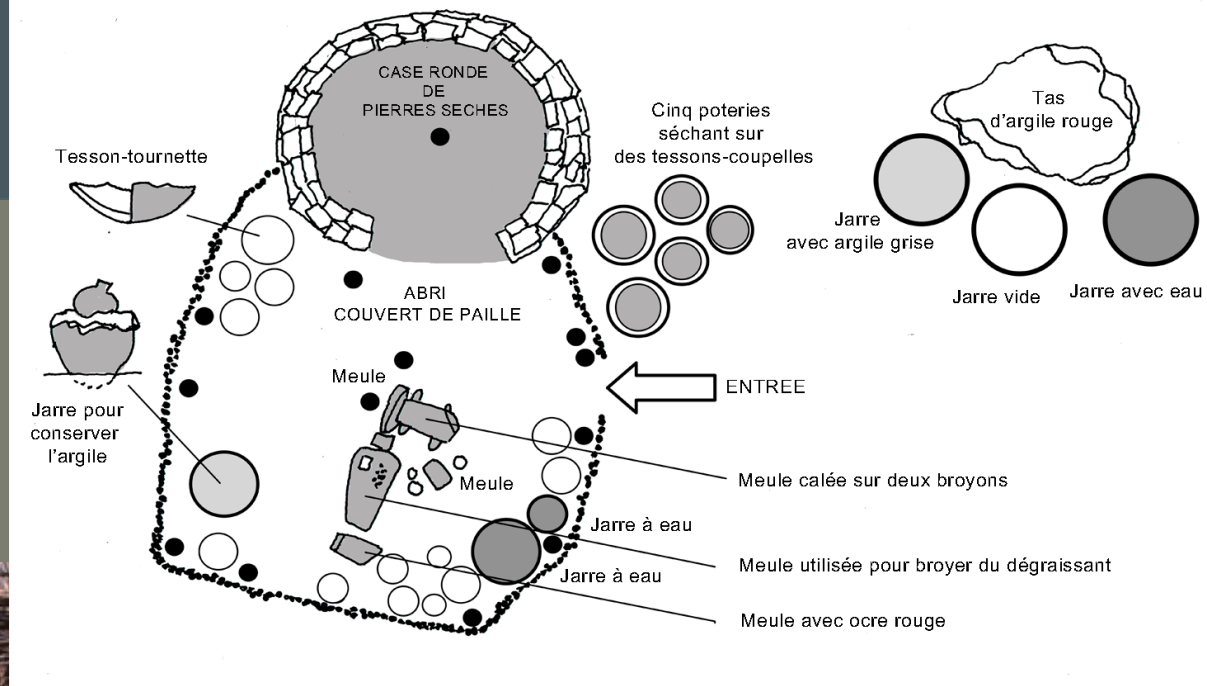

## Atelier 2

Yélé :  
ateliers de M. Djo (Djo)

# TRADITION C : fabrication

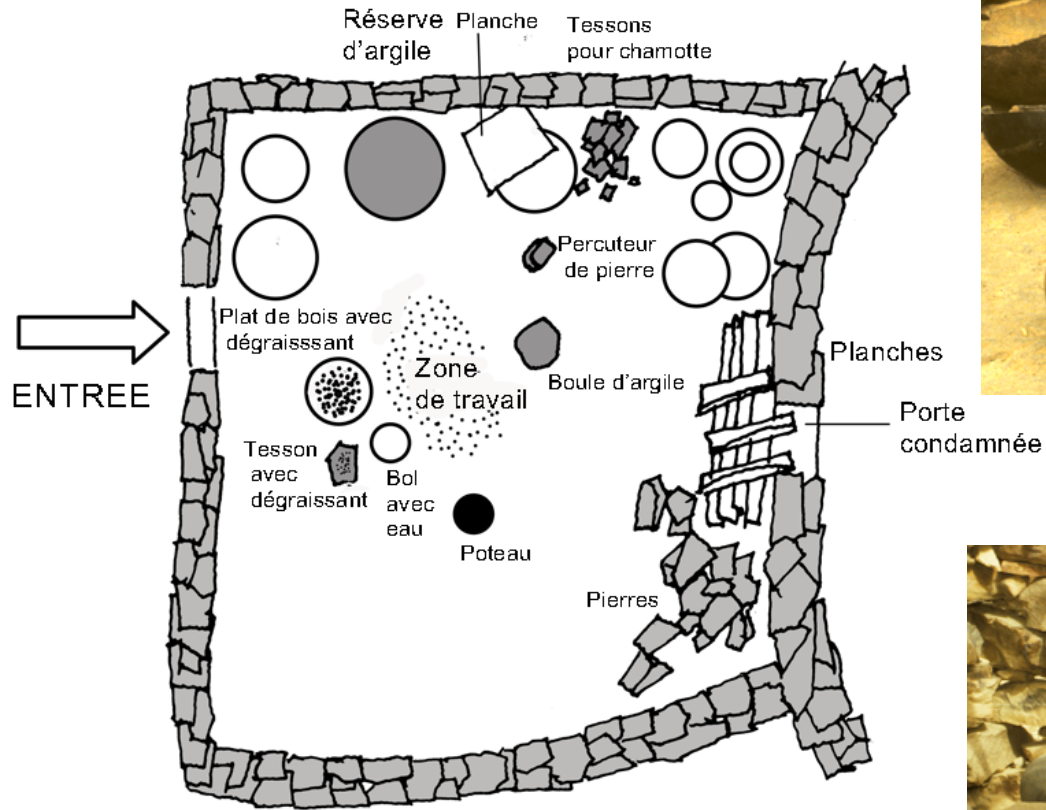

Modjodjé lé :  
atelier de T. Togo (Sobengo)

# TRADITION C : diffusion sur les marchés

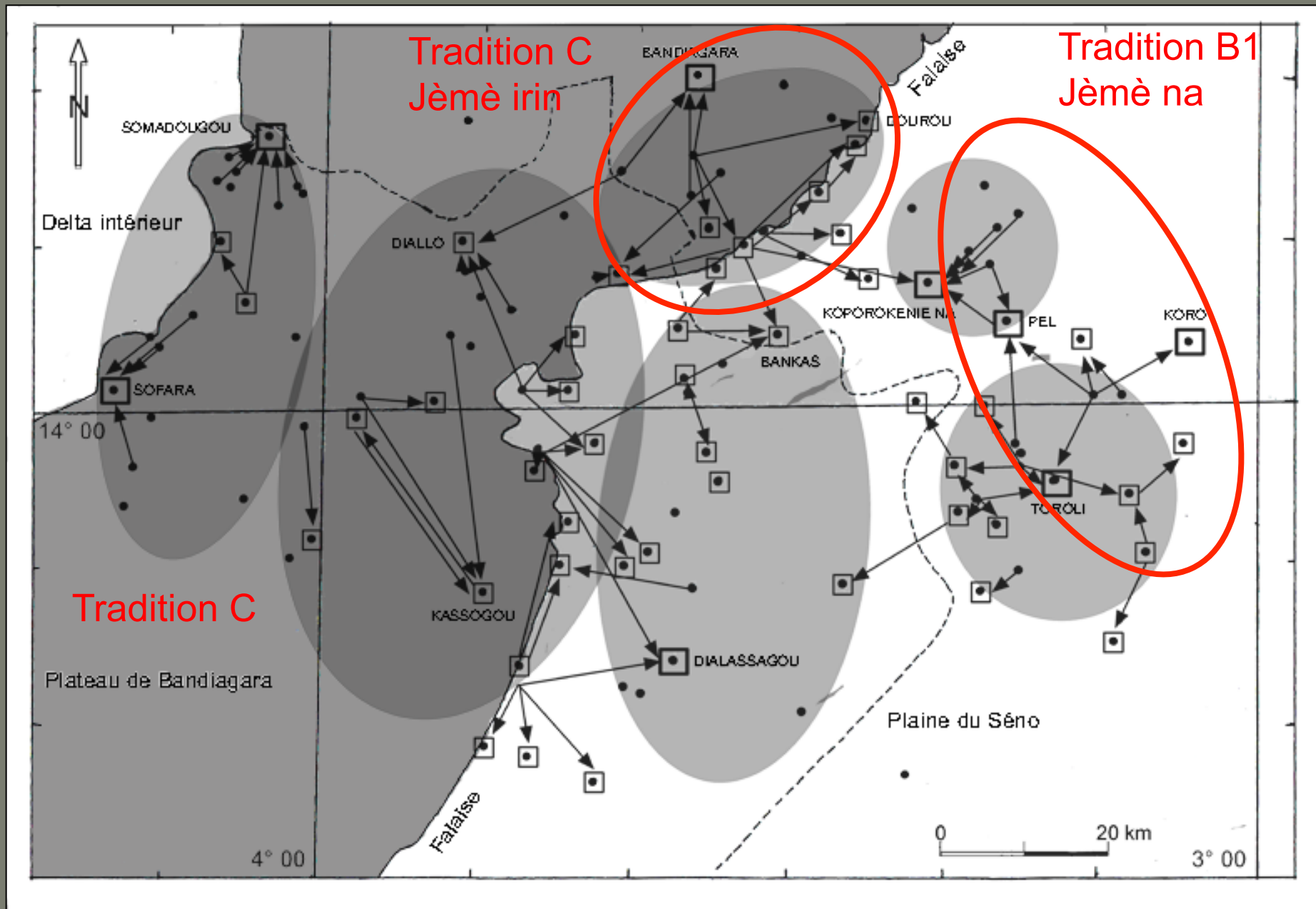



# TRADITION C : diffusion sur les marchés

Tradition C : distances aux marchés

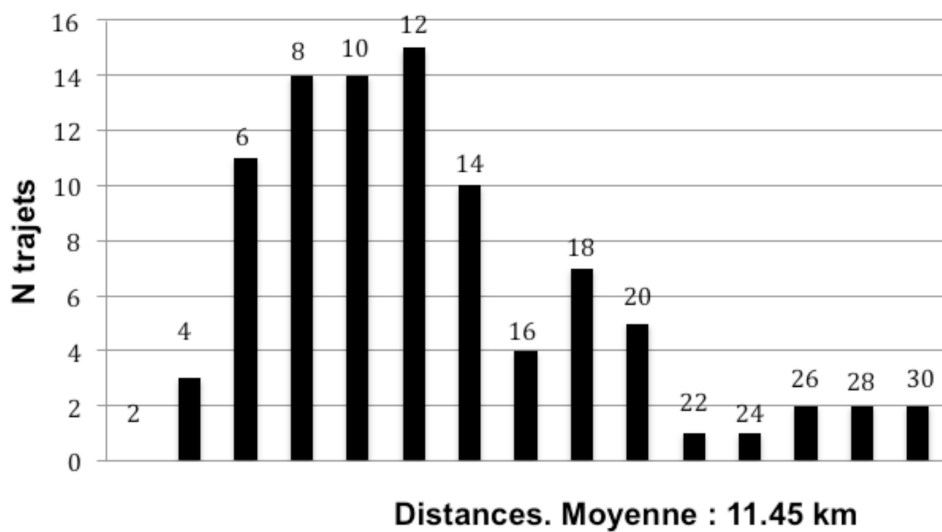

# TRADITION D : Jèmè Irin

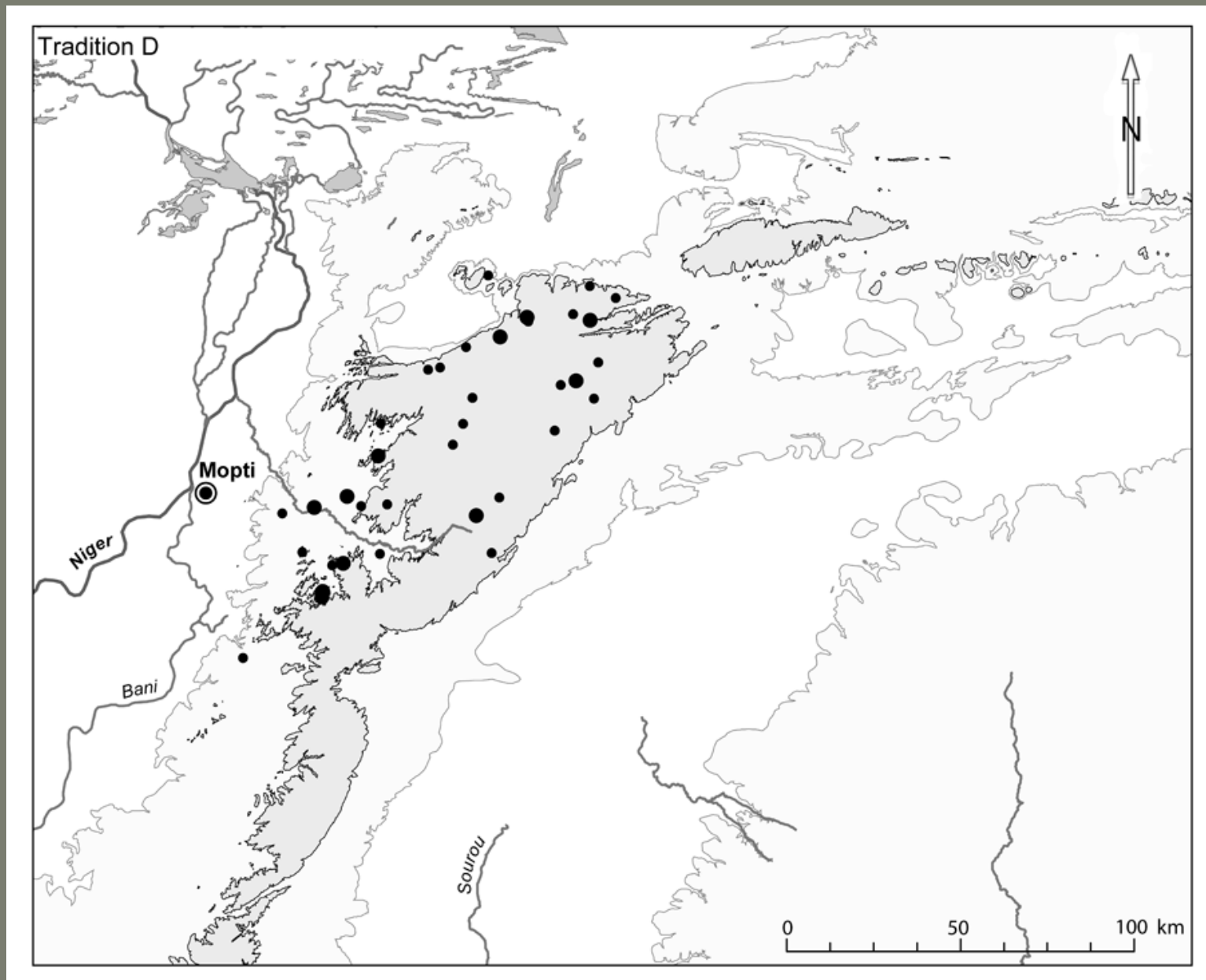

# TRADITION D : géographie

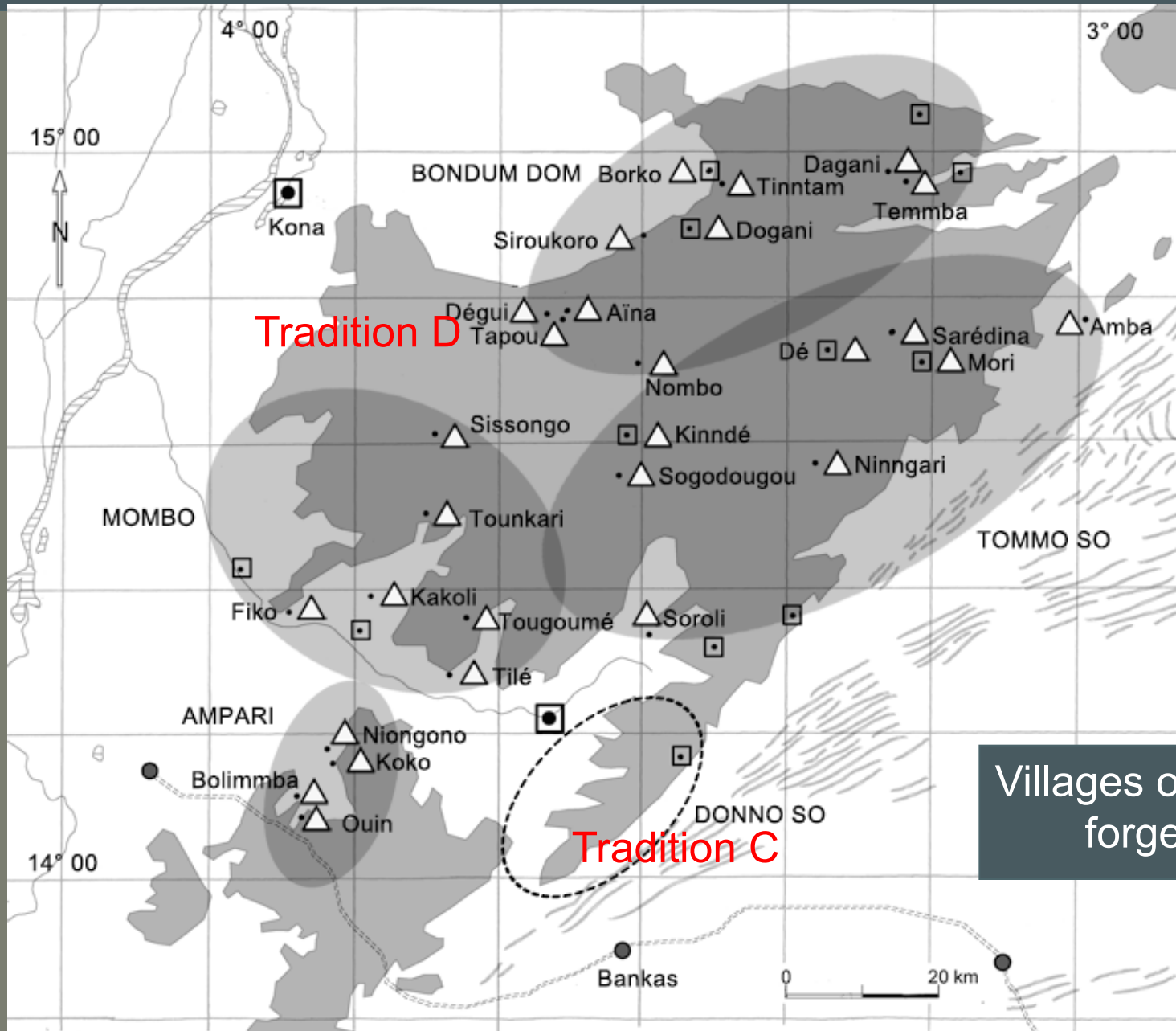

# TRADITION D : géographie

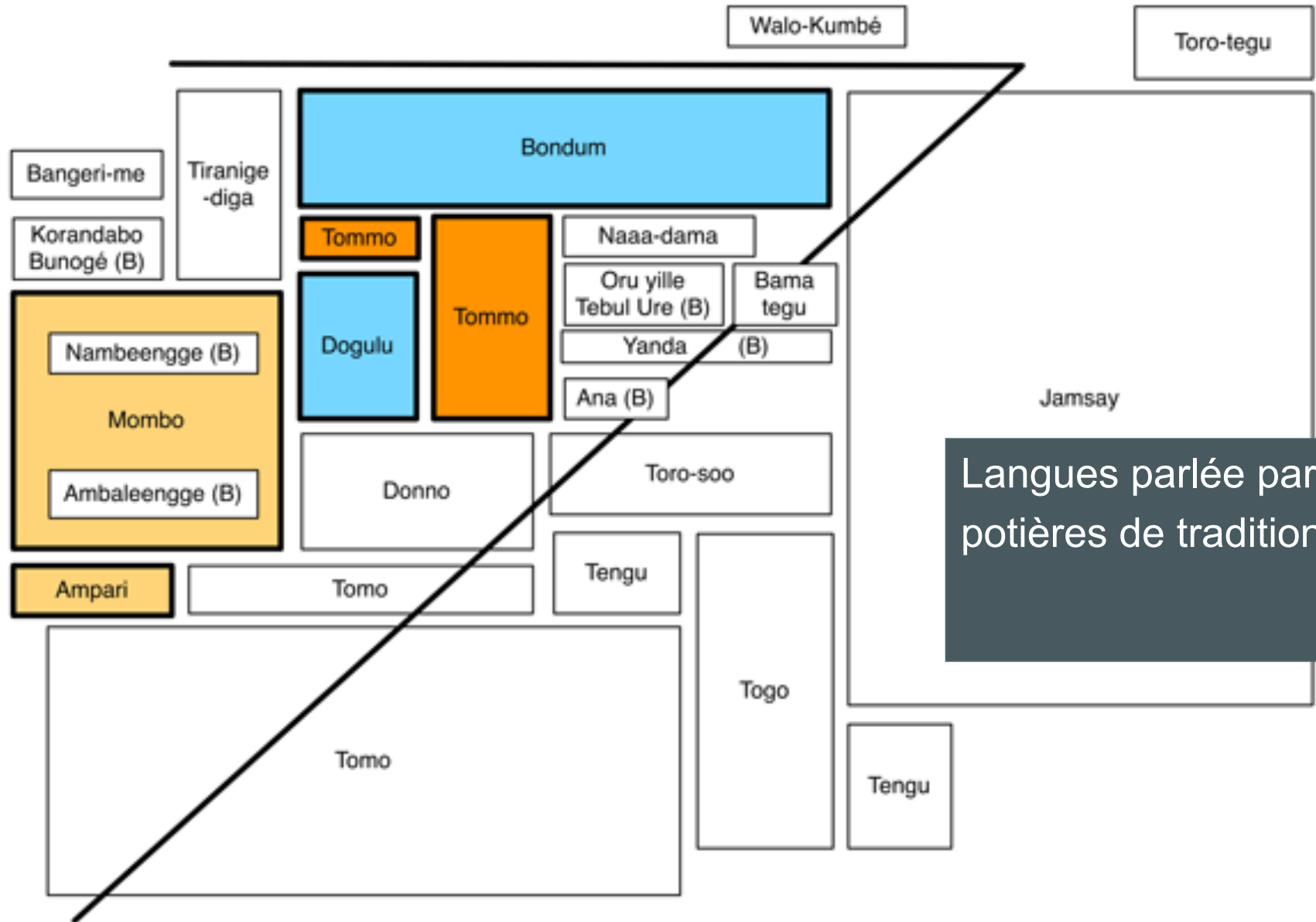

Langues parlée par les potières de tradition D

# TRADITION D : typologie

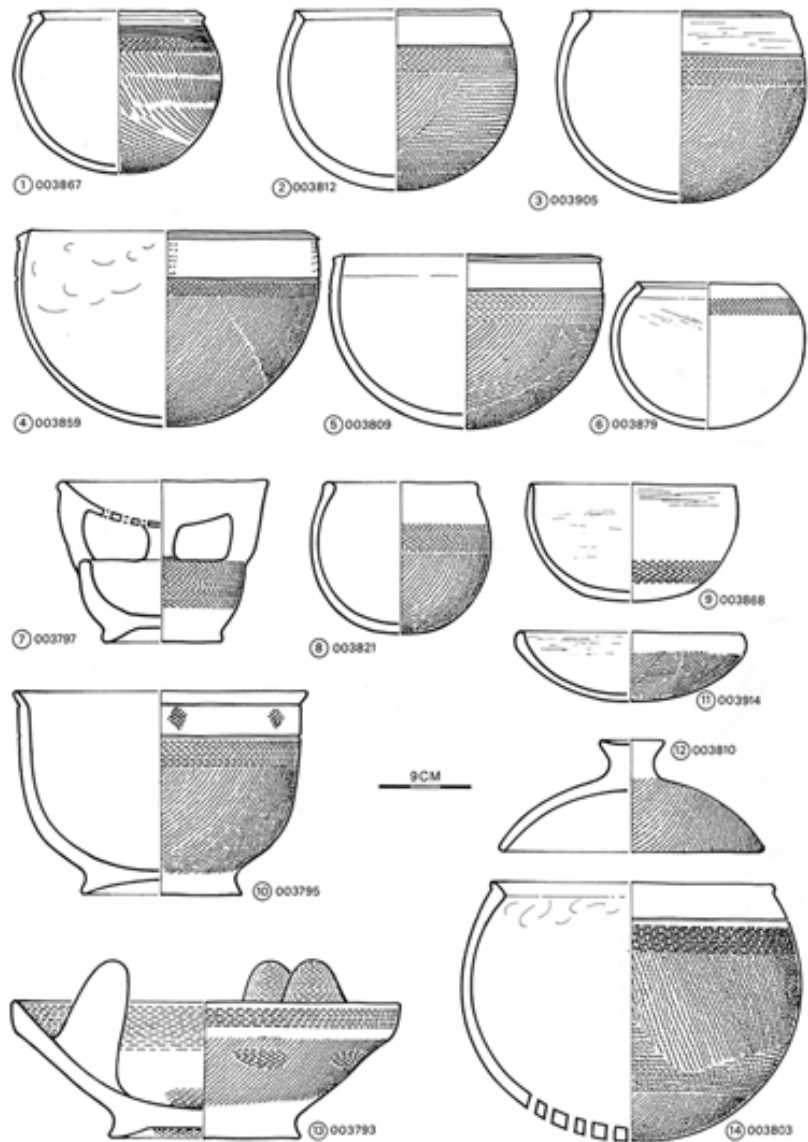

# TRADITION D : typologie

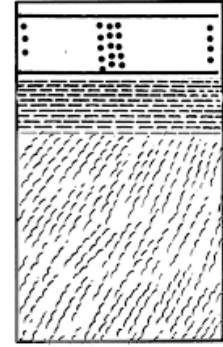
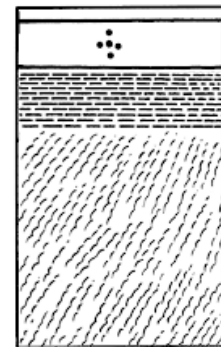
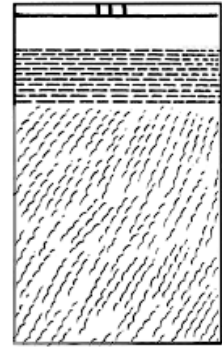
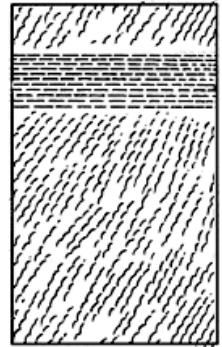
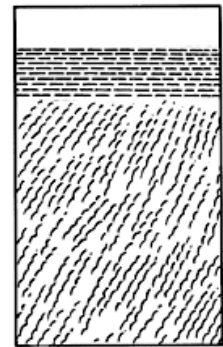
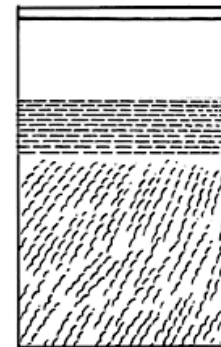
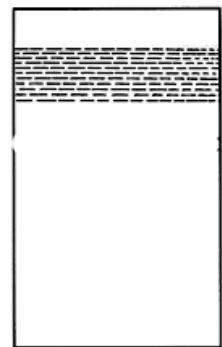
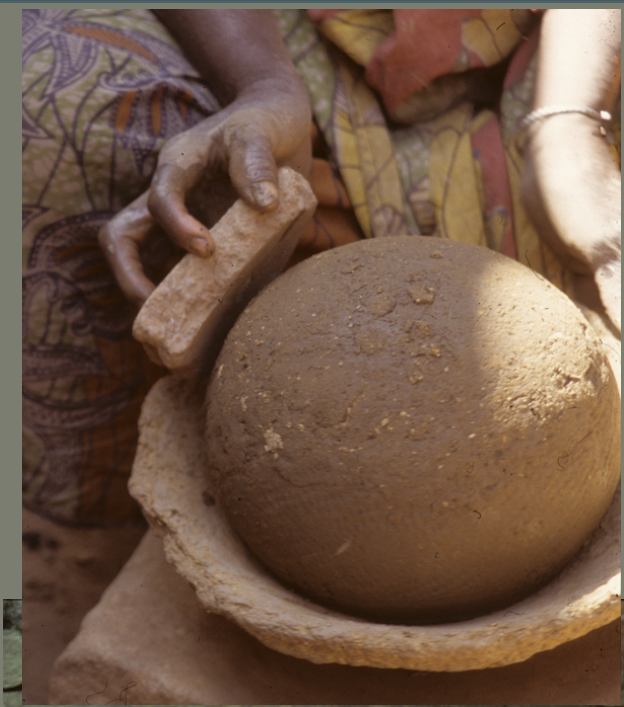

# TRADITION D : fabrication, montage, creusage

1. Cylindre à téton



2. Creusage de l'ébauche



3. Montage au colombin



# TRADITION D : fabrication, montage, creusage



4. Façonnage de la préforme



5. Finition du fond



6. Bord



# TRADITION D : fabrication, montage, creusage

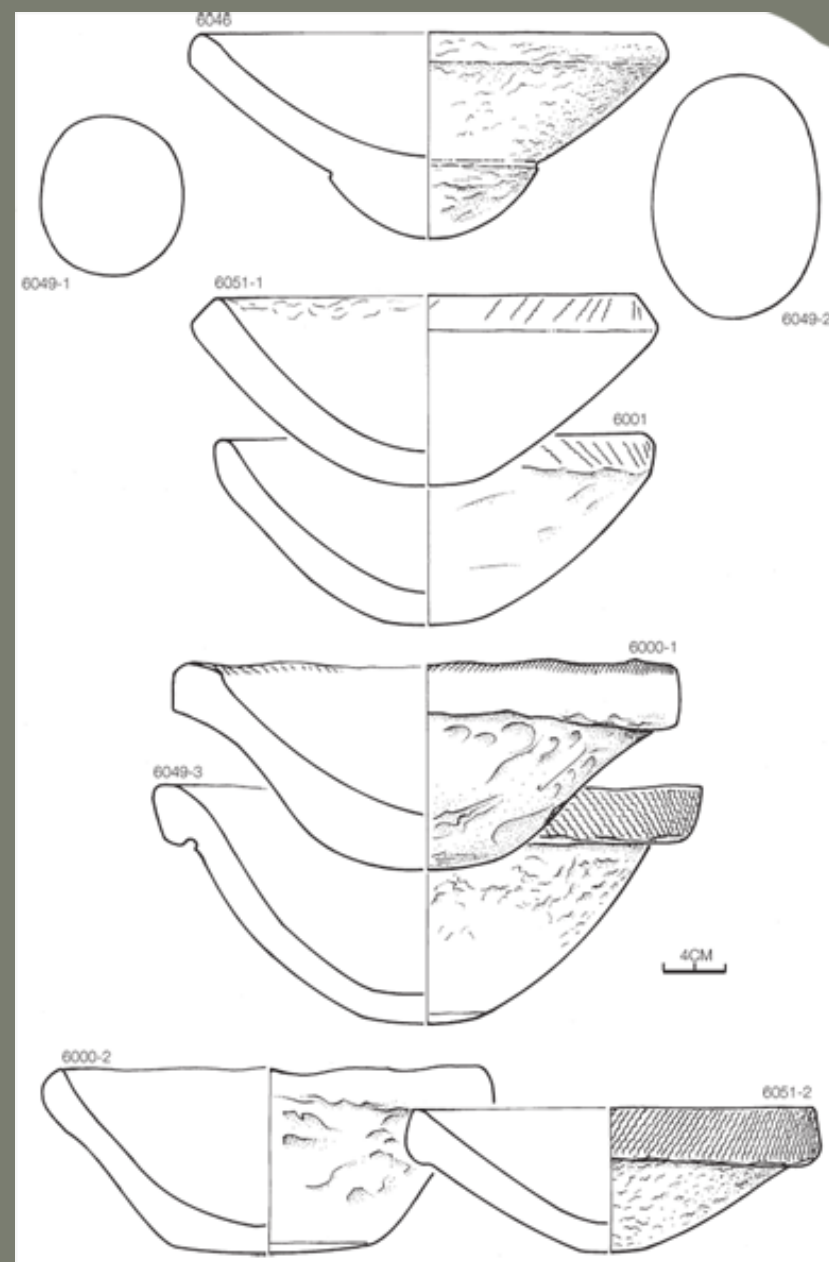
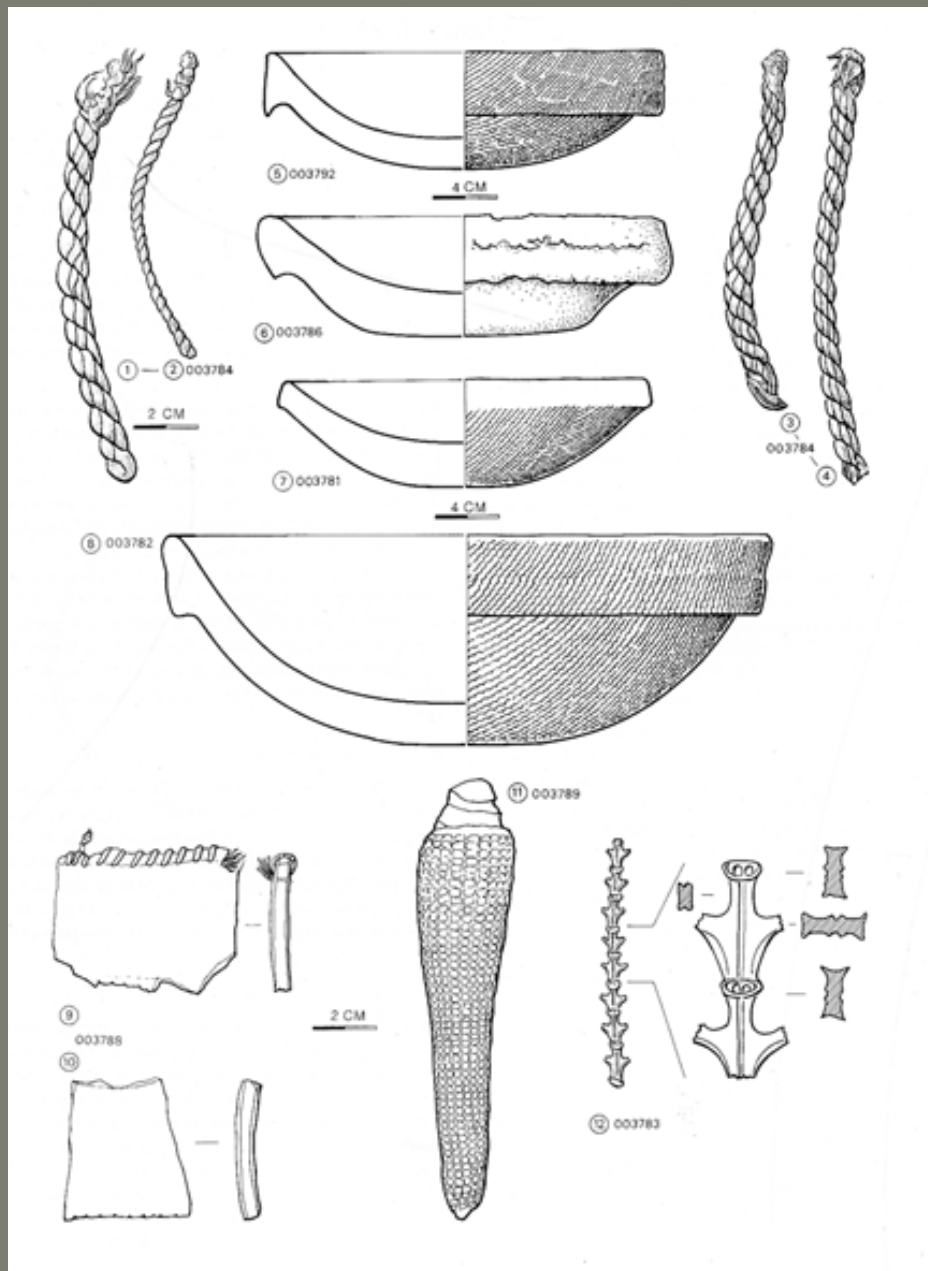

# TRADITION D : fabrication, cuisson, Jèmè irin



# TRADITION D : fabrication, cuisson, Jèmè irin

DOGON D  
Niongono

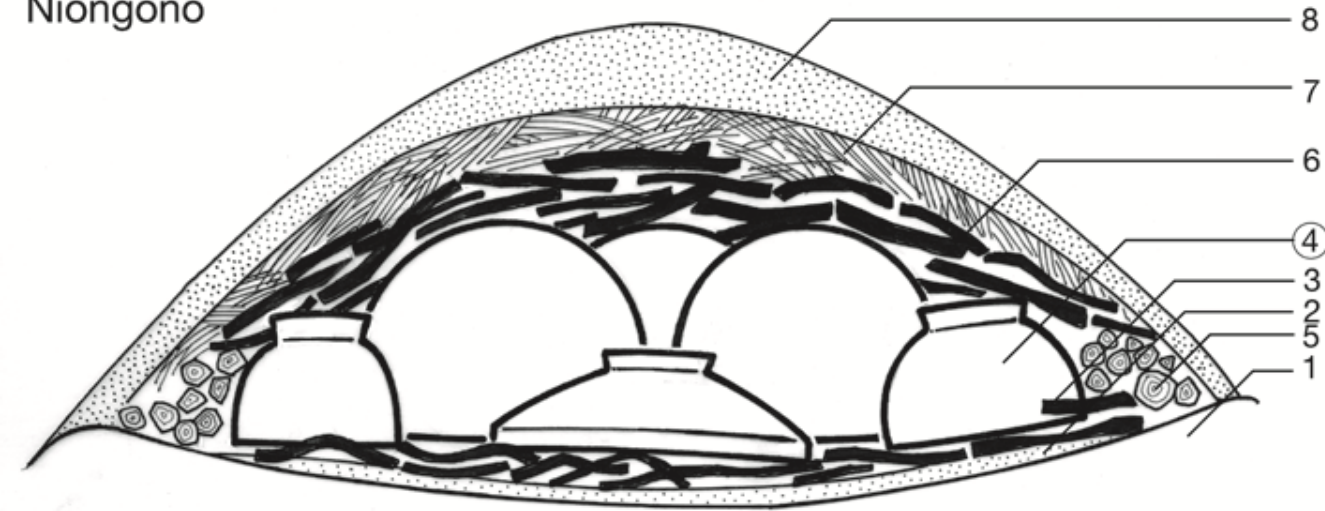

1. Légère dépression
2. Bale de mil
3. Ecorces
4. **Poteries**
5. Couronne de branches
6. Petites branches et écorces
7. Paille
8. Bale de mil

# TRADITION D : transmission, Jèmè irin



Distances matrimoniales

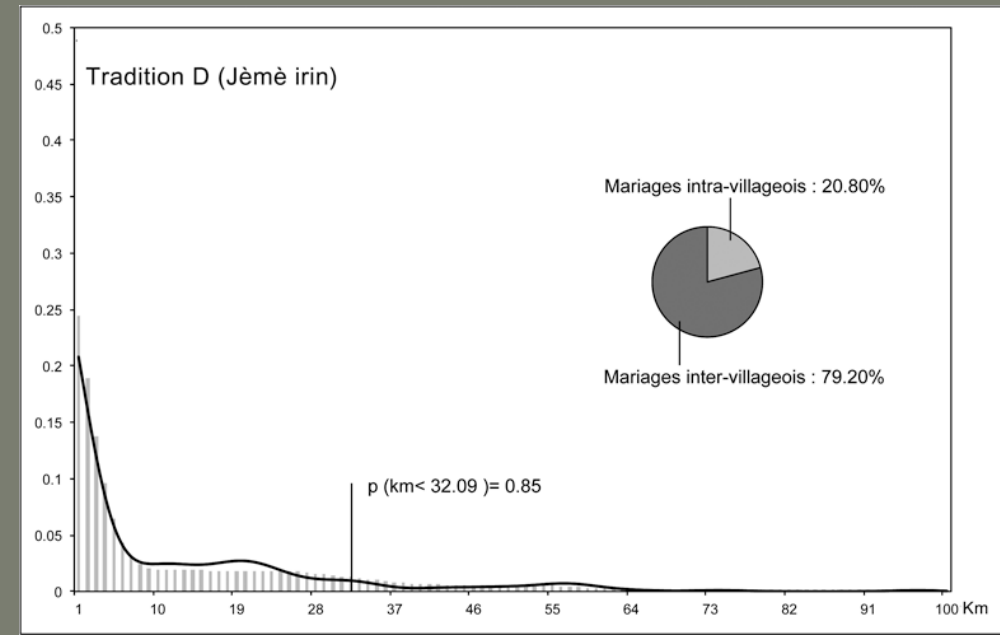
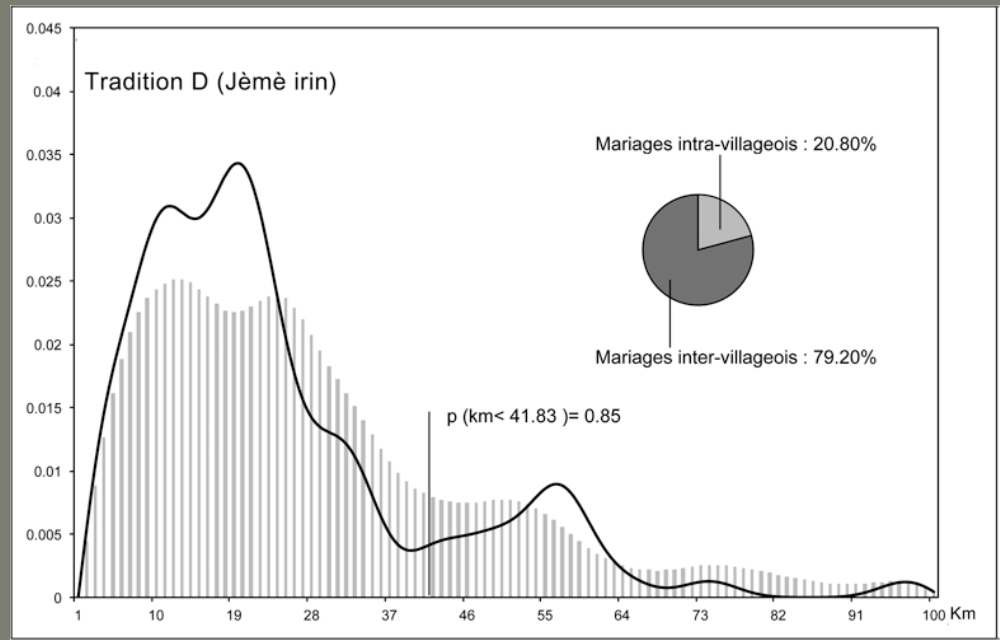

# TRADITION D : transmission, Jèmè irin

## POTIERES

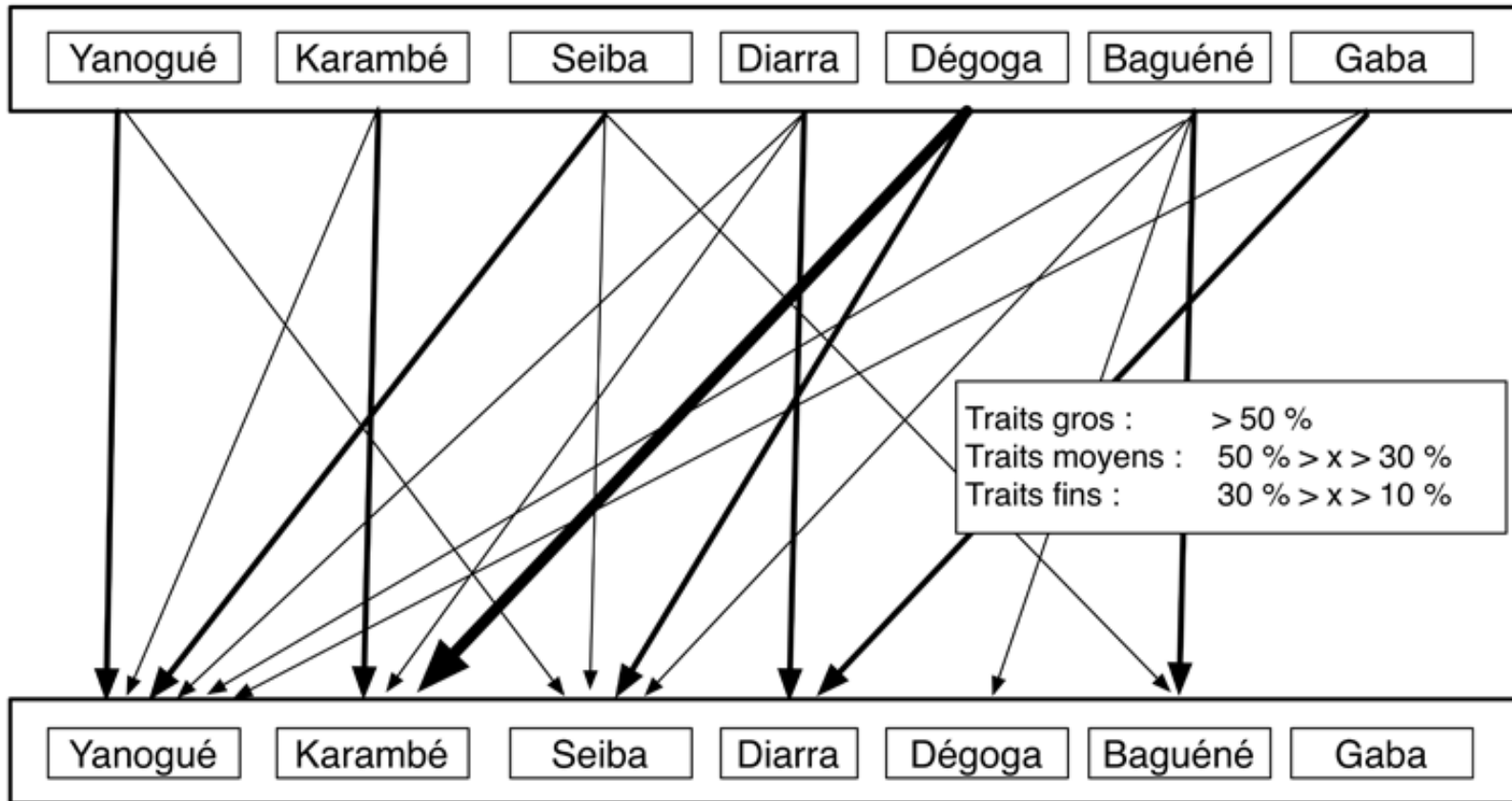

## FORGERONS

# TRADITION D : transmission, Jèmè irin

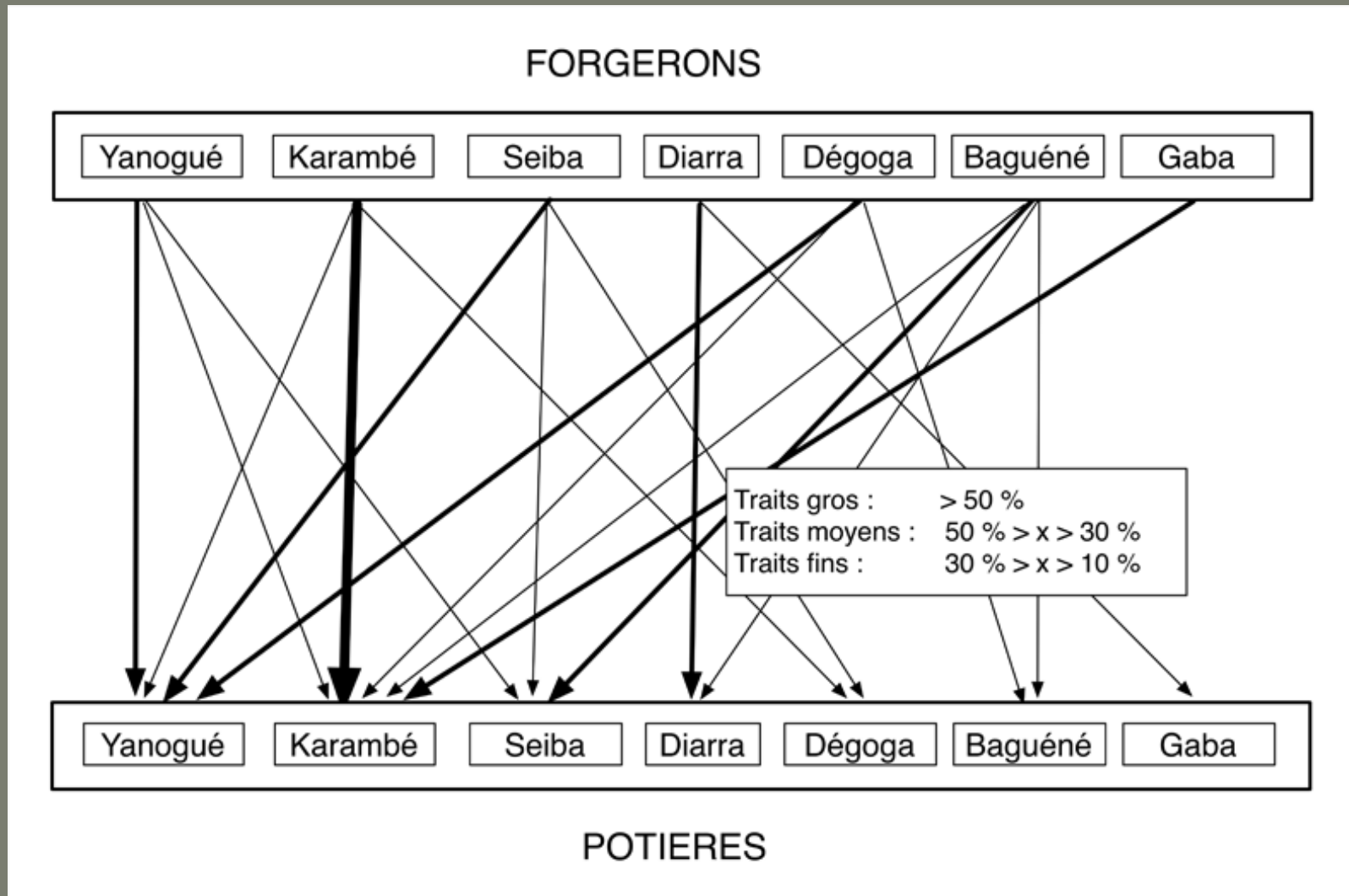

la tendance à l'endogamie patronymique des potières de tradition D se monte à seulement à 34,6% bien que, pour chaque famille, les mariages les plus nombreux se situent souvent à l'intérieur de la famille.

# TRADITION D : transmission, Jèmè irin

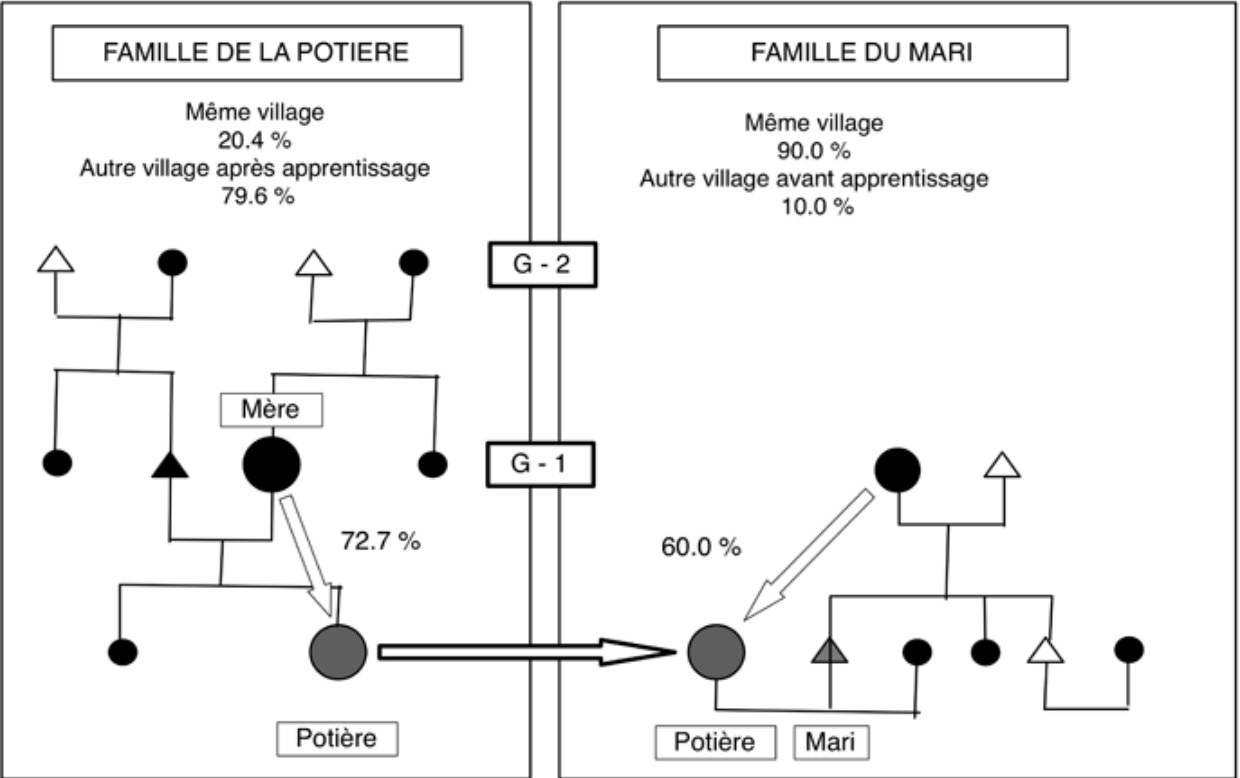

# TRADITION D : transmission, Jèmè irin

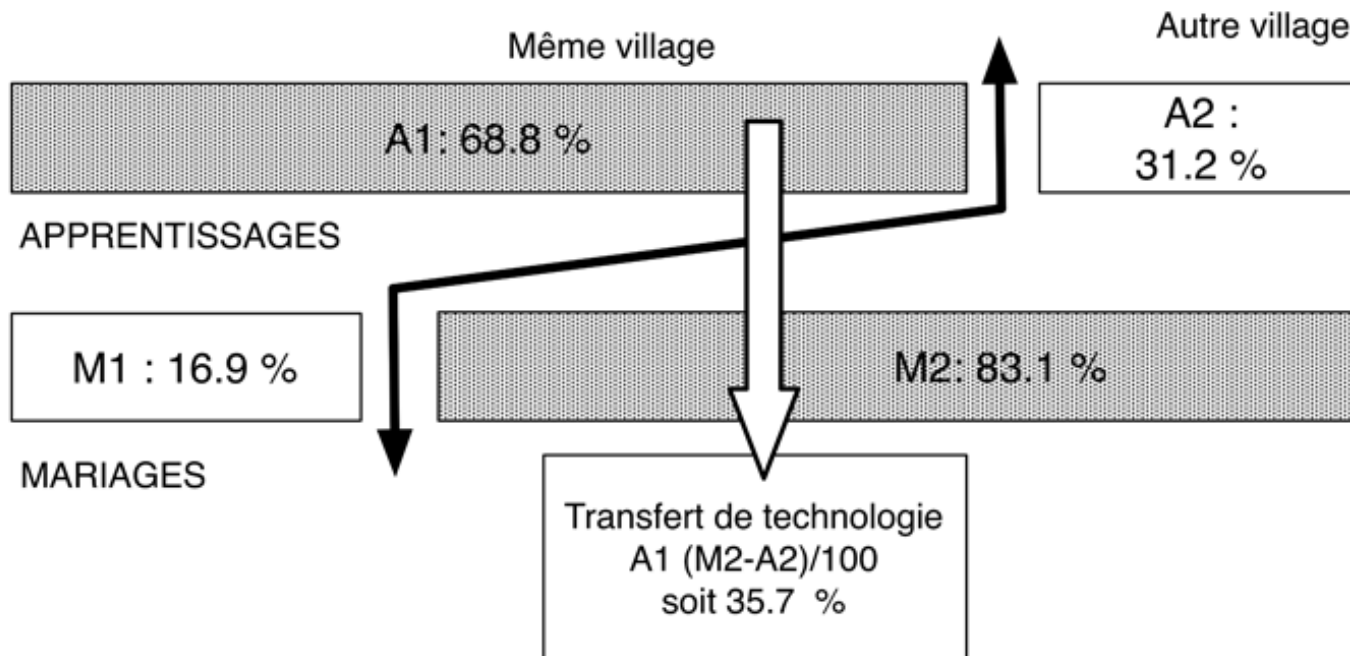
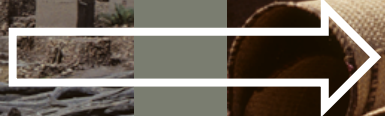

A : 22.4 %  
D : 35.7 %  
C : 46.5 %  
B1 : 60.6 %  
B2 : 60.7 %



# TRADITION D : diffusion, Jèmè irin

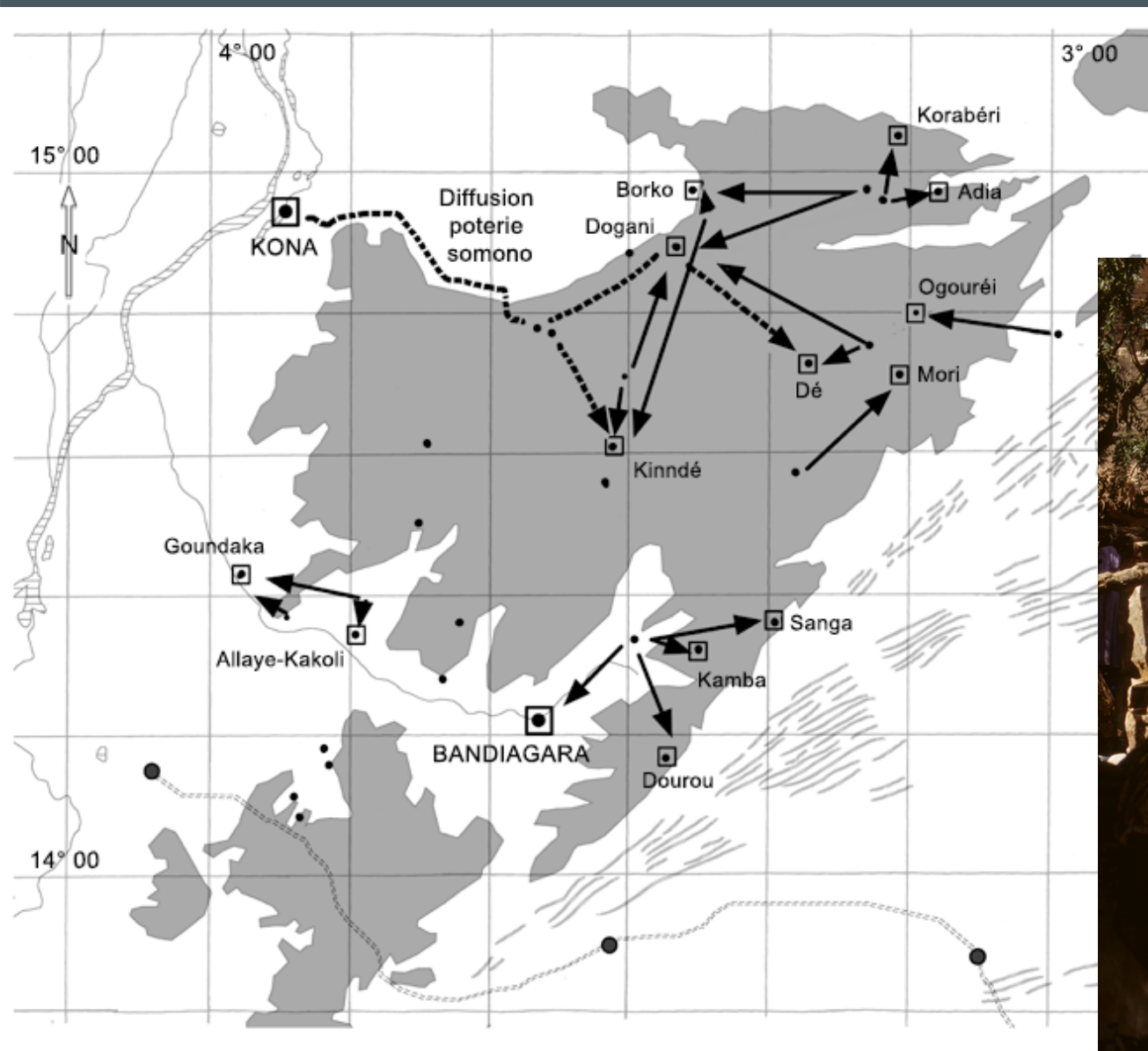

Marché de Kinndé

Tirets : commercialisation de la céramique somono de Kona

# TRADITION D : diffusion, Jèmè irin

TRADITION D									Total
Diffusion intravillageoise	oui	oui							
Vente dans villages extérieurs		oui	oui	oui	oui				
Vente sur le marché du village			oui	oui		oui	oui		
Vente sur les marchés extérieurs				oui	oui		oui	oui	
N	31	8	1	-	13	7	3	3	66
%	47.0	12.1	1.5	-	19.7	10.6	4.5	4.5	
Diffusion intravillageoise	31 (47 %)								
Diffusion “villageoise”		8 (12.1 %)							
Diffusion “marchande”			27 (41.0 %)						

# TRADITION D : diffusion, Jèmè irin

## Tradition D : villages extérieurs

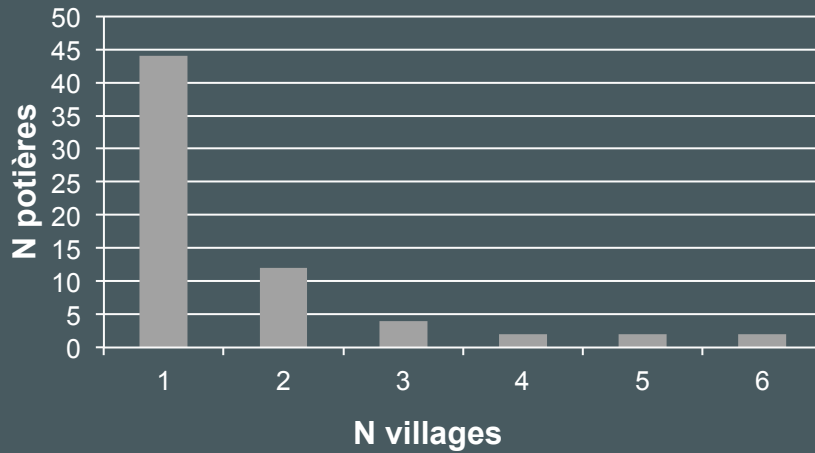

## Tradition D : marchés extérieurs

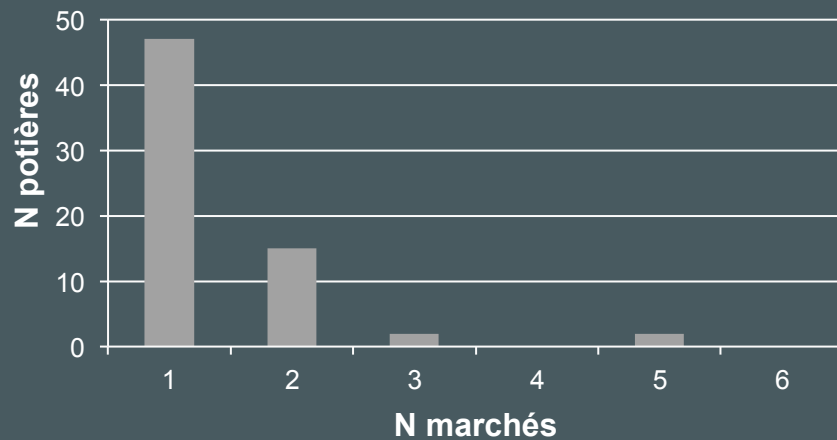

## Tradition D : distances aux marchés

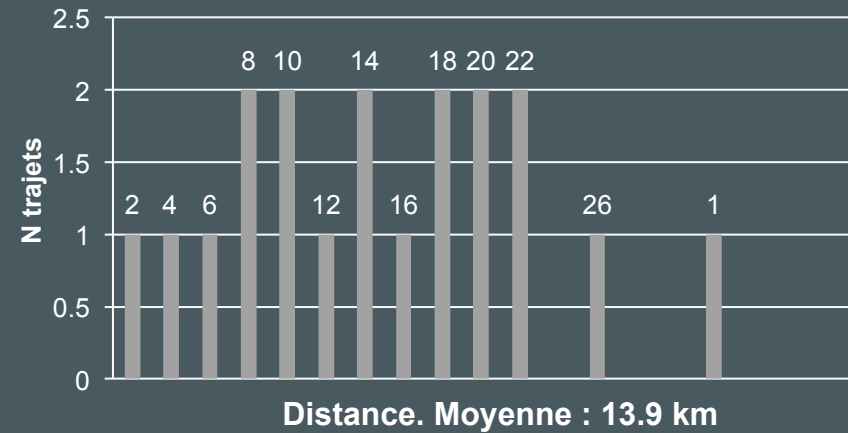

# TRADITION D : commercialisation de la poterie somono de Kona

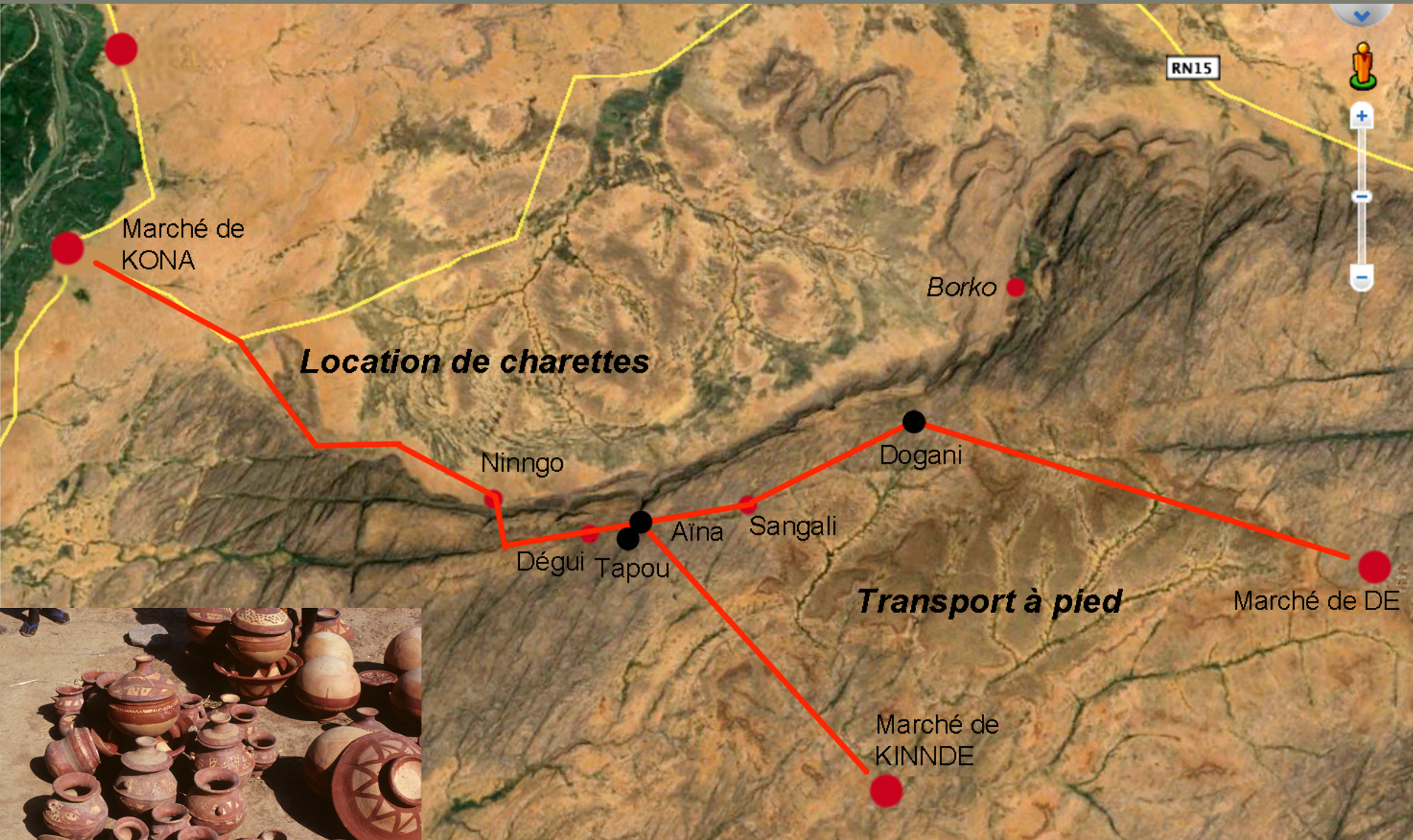

Un cas unique de commercialisation par des femmes d'agriculteurs

# TRADITION D : diffusion, Jèmè irin

	Toumbouro	Dogani Bèlè
Tresse roulée	8 (2.4 %)	--
Tradition D	<b>265 (78.4 %)</b>	20 (22.5 %)
Tradition A	12 (3.5 %)	<b>44 (49.4 %)</b>
Poterie de Kona	2 (0.6 %)	<b>18 (20.2 %)</b>
Non attribuables	51 (15.1 %)	7 (7.9 %)
	338 (100 %)	89 (100 %)

Toumbouro : royaume de Ségou 18-19<sup>ème</sup> siècle

Dogani Bèlè : empire peul du Massina 19<sup>ème</sup> siècle

# TRADITION E : agriculteurs dogon et Peul rimaïbé

GOUMA-DES-MONTS

Hombori

Tradition sonrai  
du Hombori

RN15

Boni

Nokara

Tabi

Tradition E

Sarnyéré

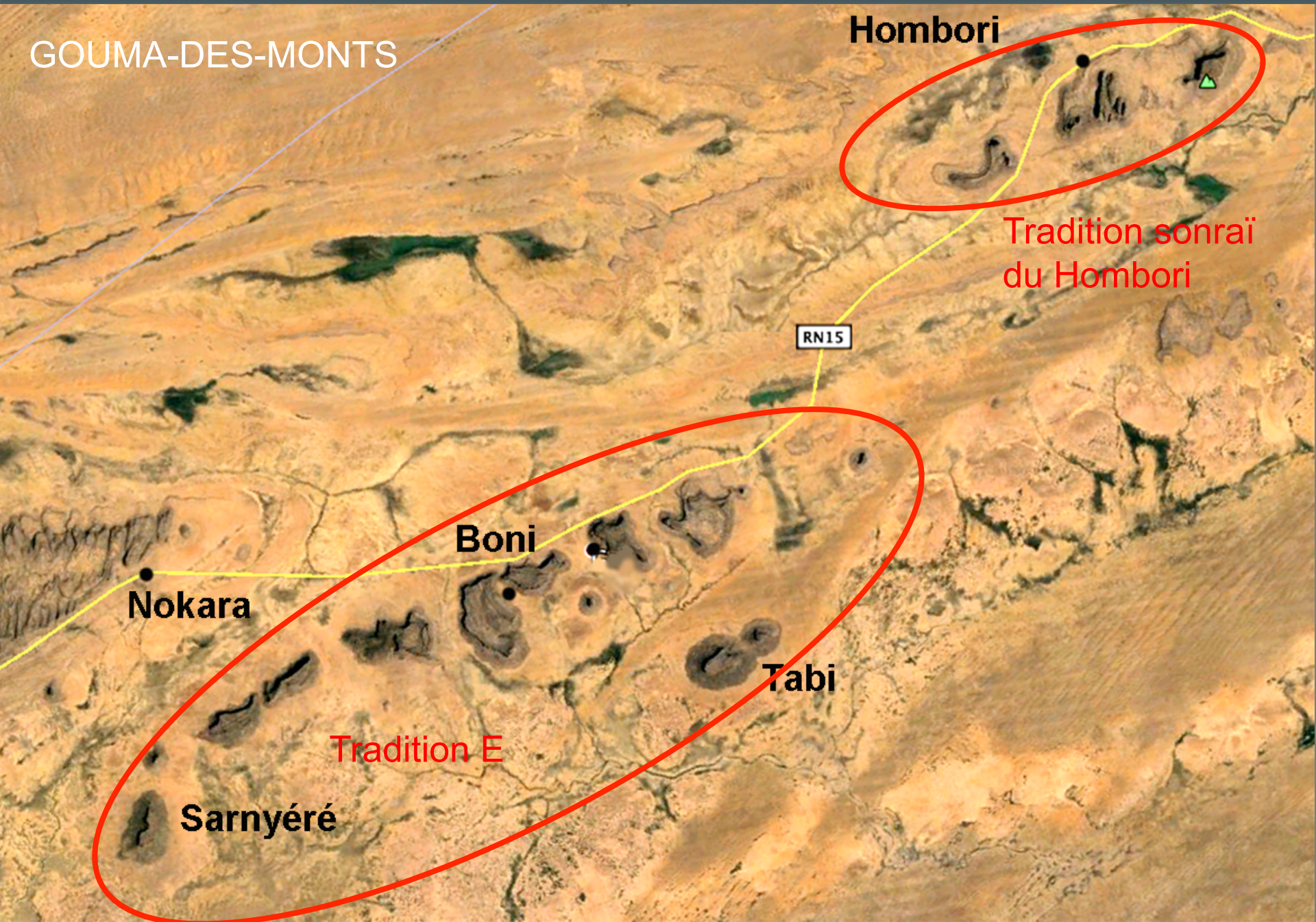

# TRADITION E : agriculteurs dogon et Peul rimaïbé



En plaine : villages Rimaïbé



Dans les montagnes : villages dogon



# TRADITION E : agriculteurs dogon et Peul rimaïbé

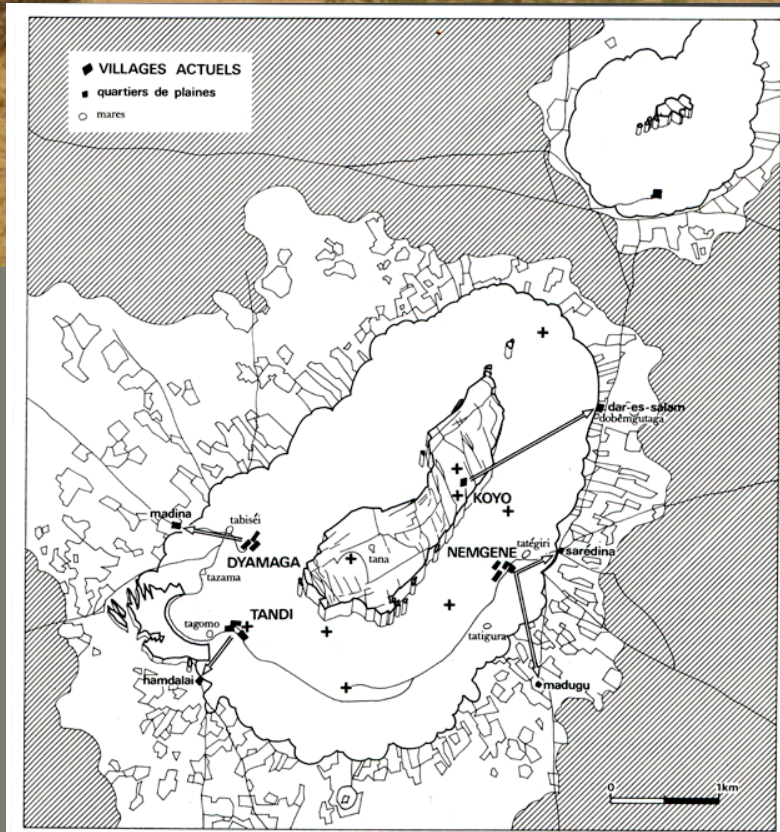

## Montagne du Sarnyéré Mission 1976

Recherche sur les grandes civilisations

Mémoire n° 4

### LE SARNYERE DOGON ARCHEOLOGIE D'UN ISOLAT, MALI

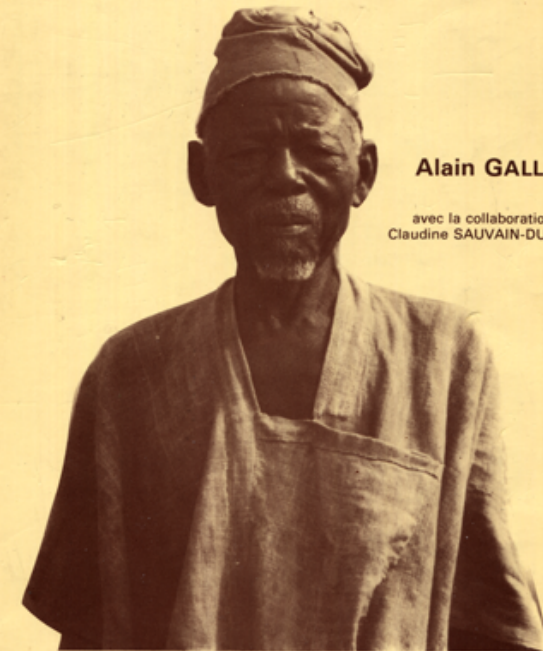

Alain GALLAY

avec la collaboration de  
Claudine SAUVAIN-DUGERDIL

AFRIQUE OCCIDENTALE

Éditions ADPF, Paris



# TRADITION E : agriculteurs dogon et Peul rimaïbé

Compléments d'enquête 2000



Mont de Tabi

# TRADITION E : typologie

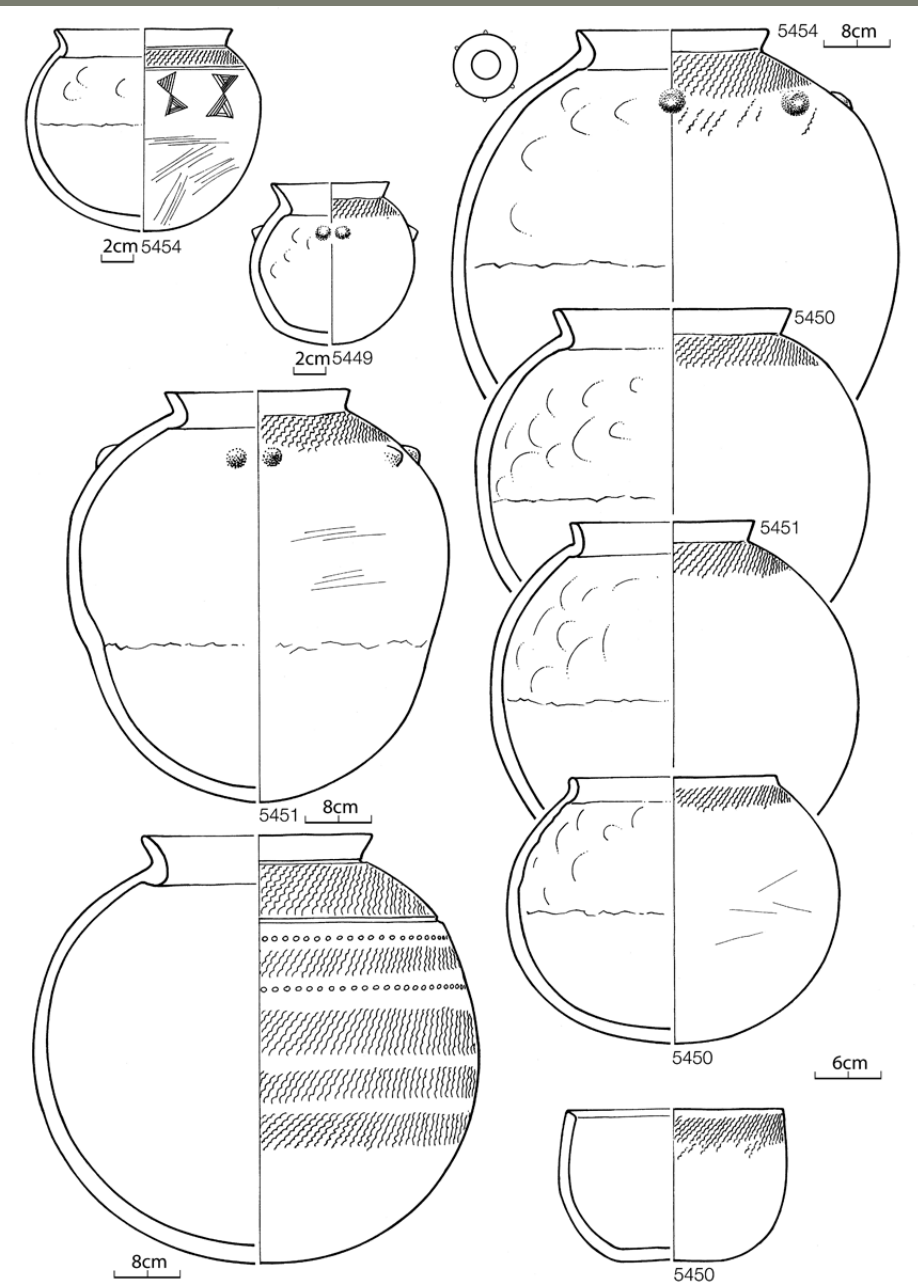

# TRADITION E : typologie

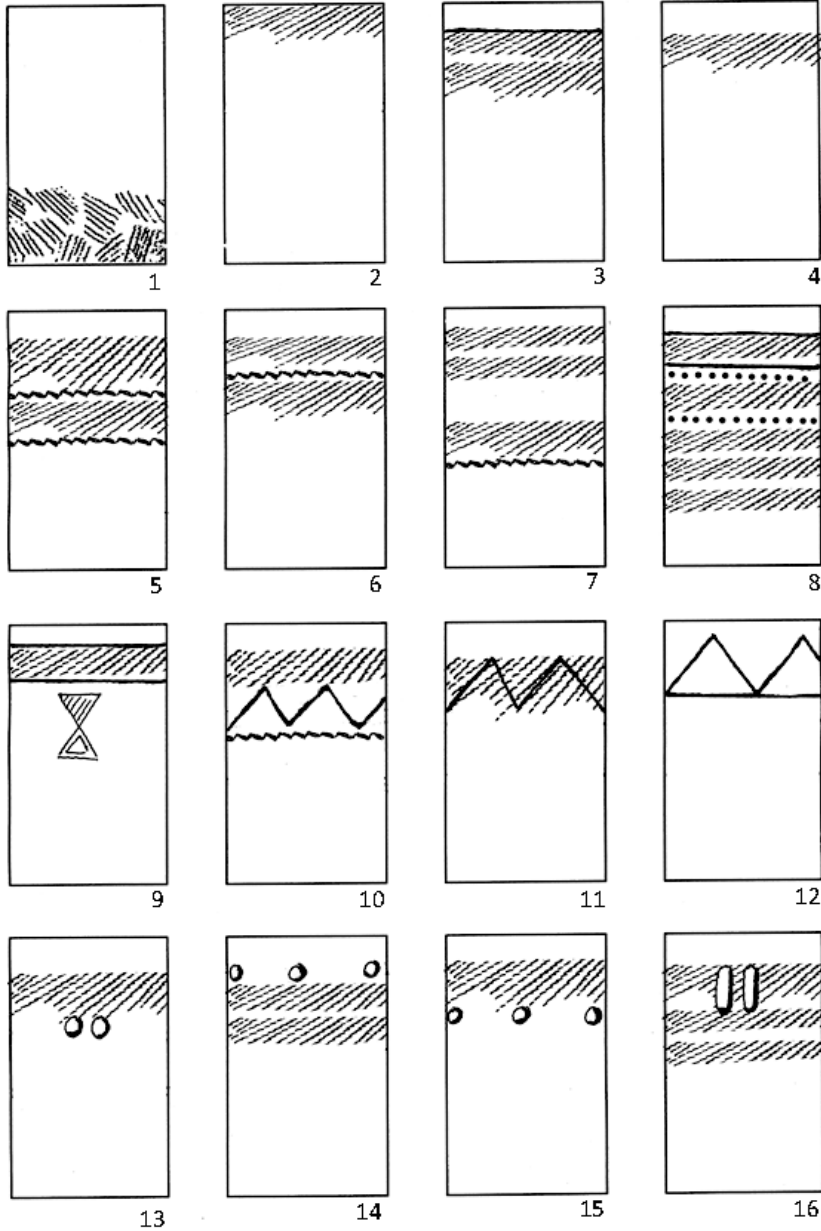

# TRADITION E : fabrication

Abri sous roche – atelier de la famille Tongo de Nemguéné (Sarnyéré)

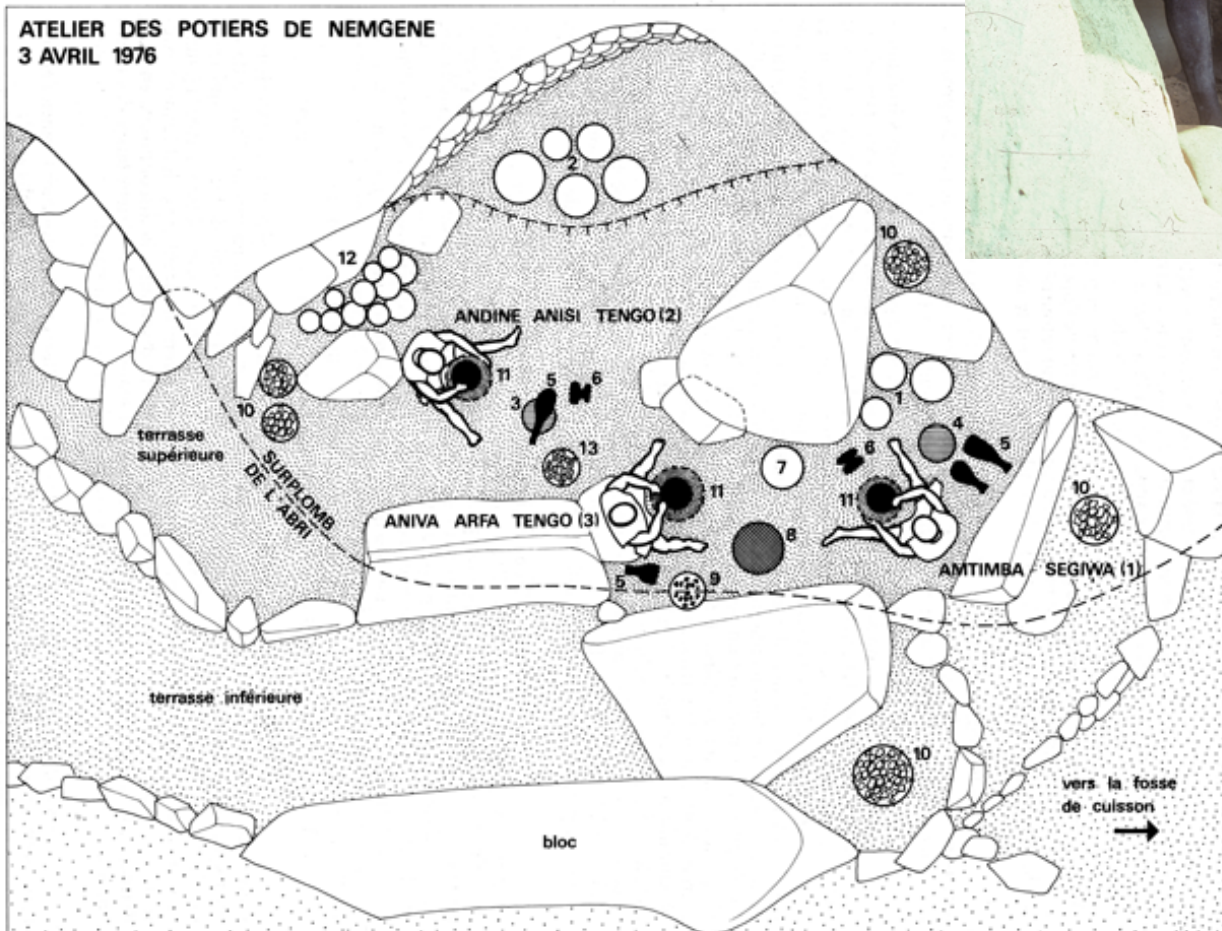



# TRADITION E : agriculteurs dogon et Peul rimaïbé



DOGON E  
Tandi

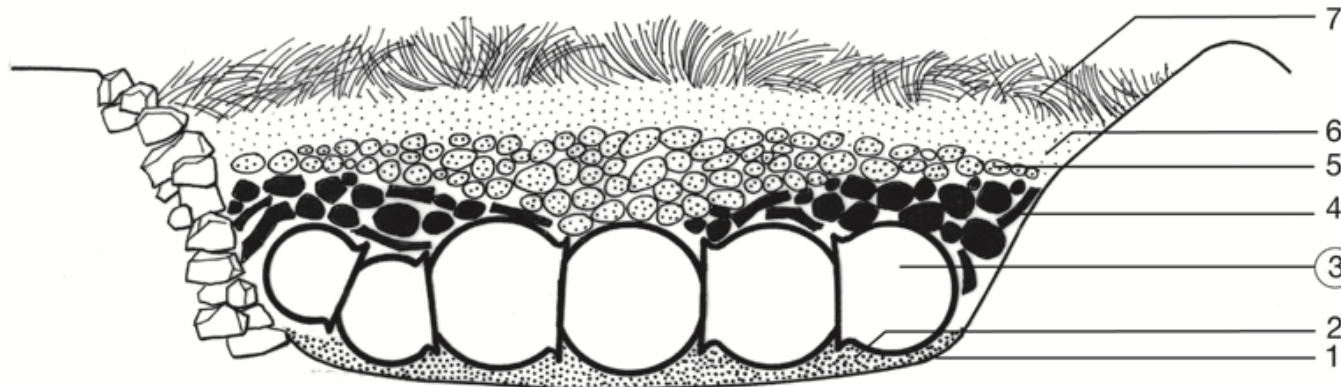

1. Fosse aménagée
2. Cendres
3. **Poteries**
4. Bois
5. Bouses
6. Bale de mil
7. Paille de mil

# TRADITION E : agriculteurs dogon et Peul rimaïbé

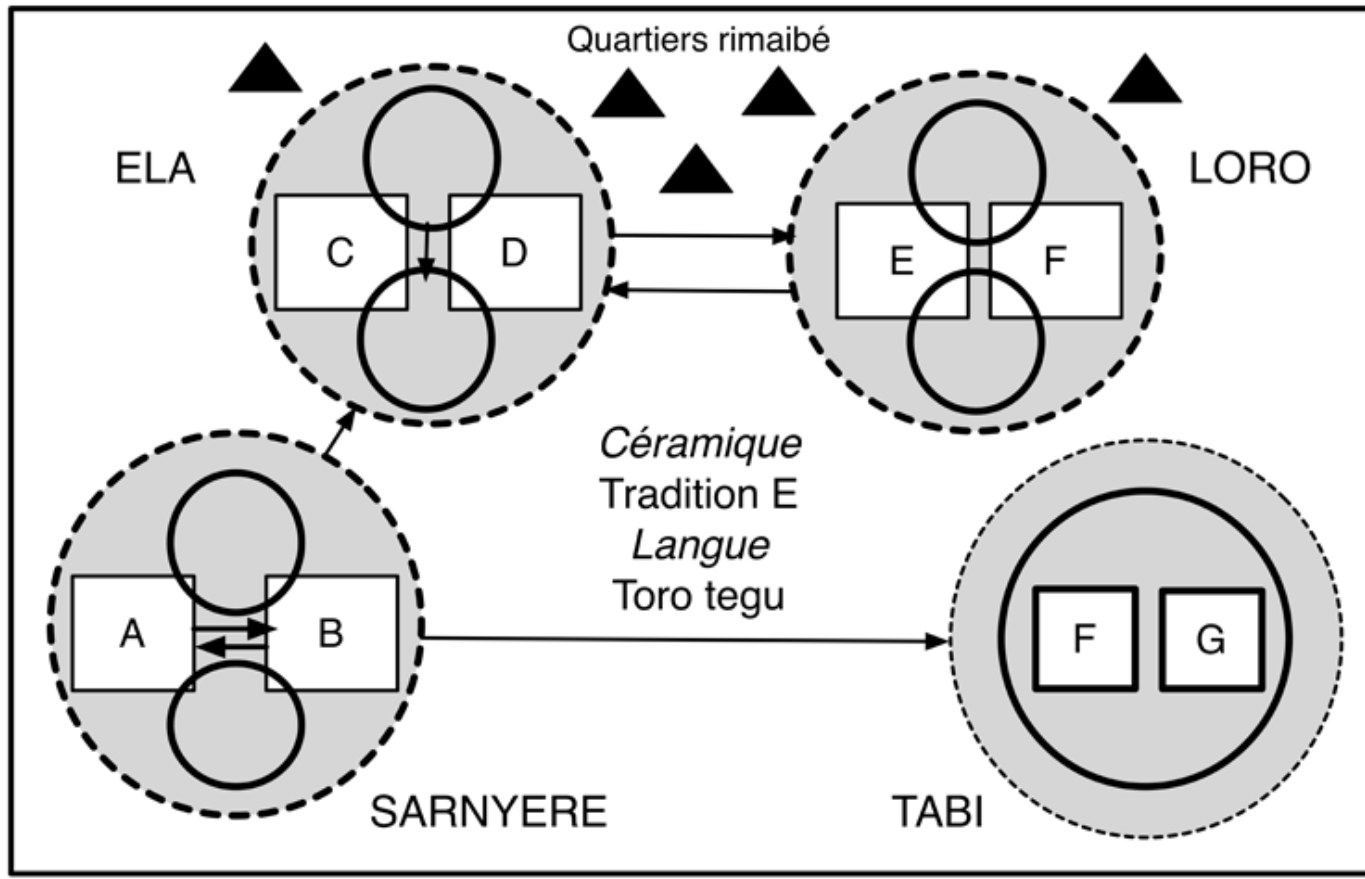

Triangles : quartiers rimaïbé

Cercles tiretés : massifs montagneux endogames

Carrés : lignages dogon

Cercles continus : villages

Flèches simples : circulation des femmes transgressant l'endogamie de massif

# TRADITION E : agriculteurs dogon et Peul rimaïbé

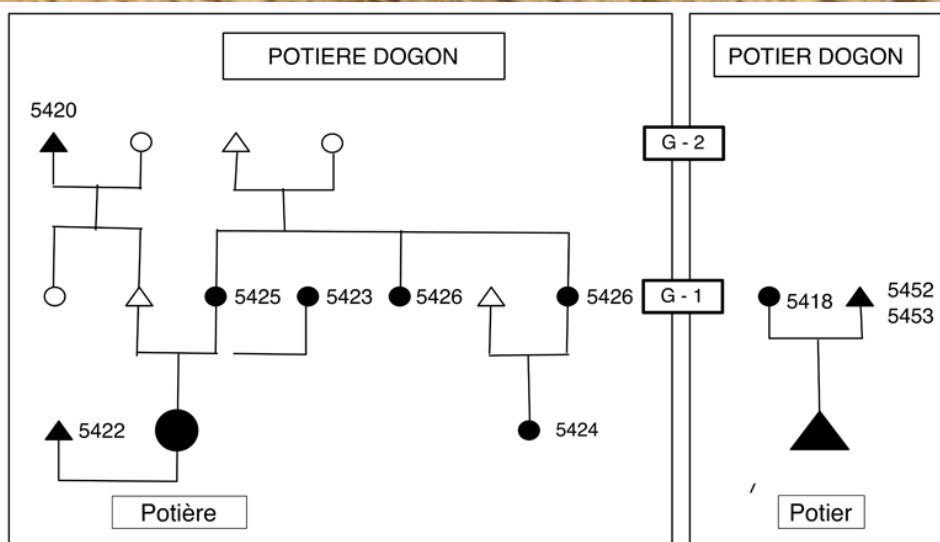

Village de naissance = village d'apprentissage = village de résidence

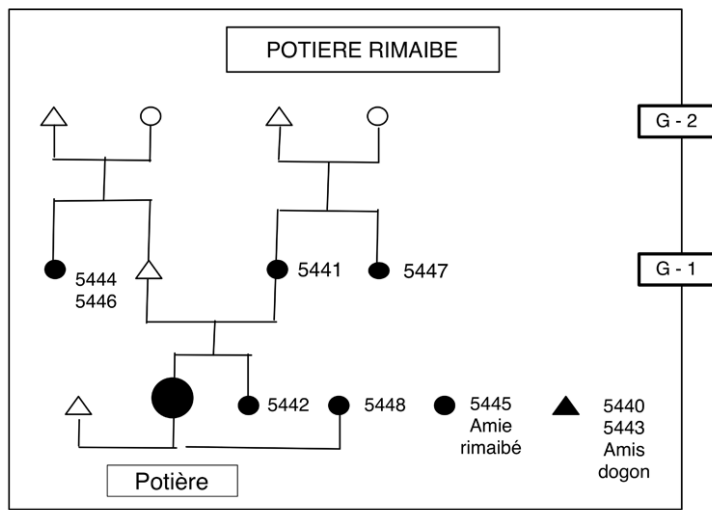

Village de naissance = village d'apprentissage = village de résidence





# TRADITION E : agriculteurs dogon et Peul rimaïbé

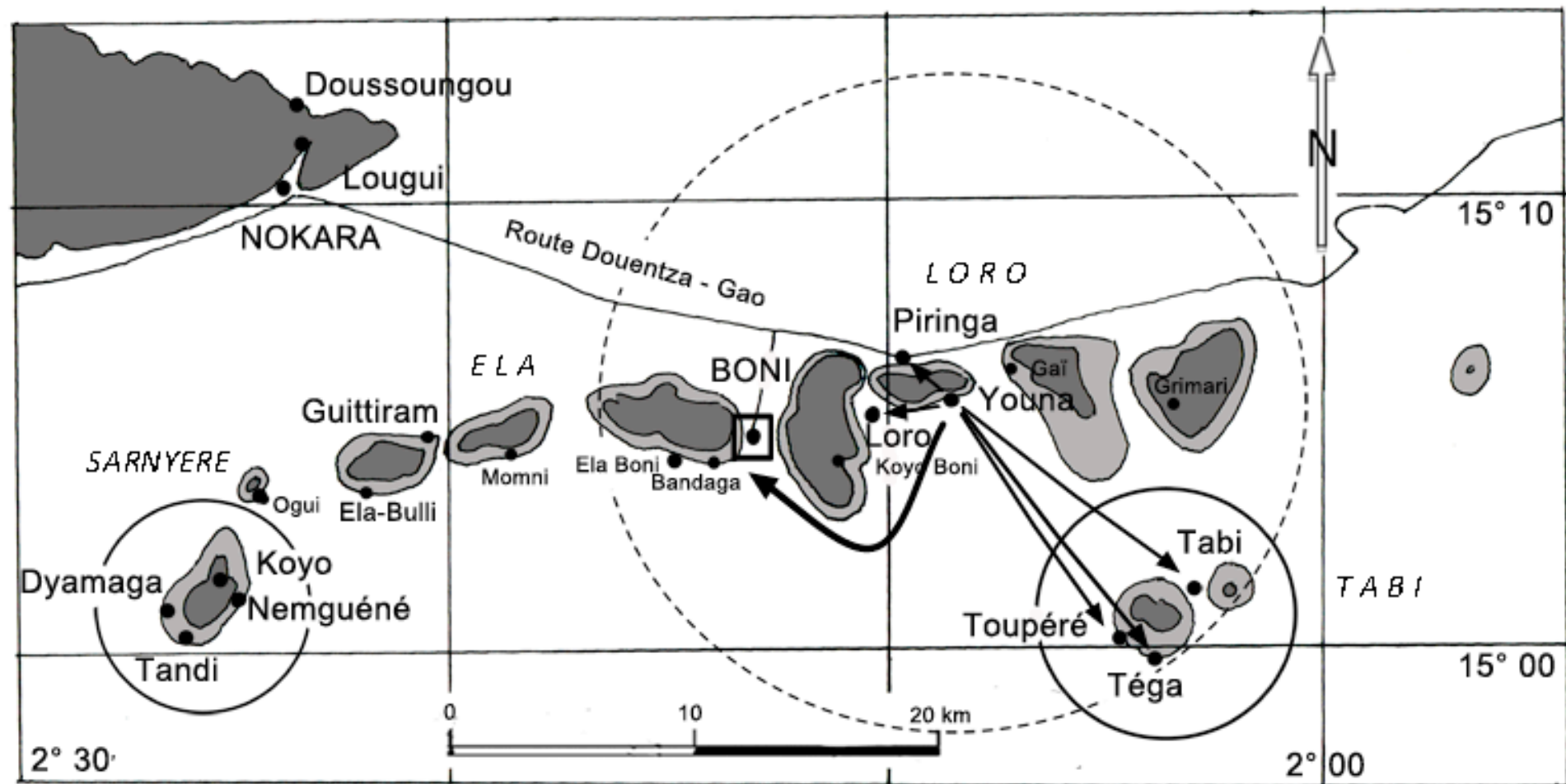

Diffusion de la céramique sur les marchés (flèche épaisse) et dans les villages (flèches minces)

# TRADITION E : agriculteurs dogon et Peul rimaïbé

